



Precision Motion Control Solutions

STAGES FOR MEDIUM LOADS AND TRAVEL RANGES TO 300 MM

L-406 Compact Linear Stage

For loads up to 10 kg

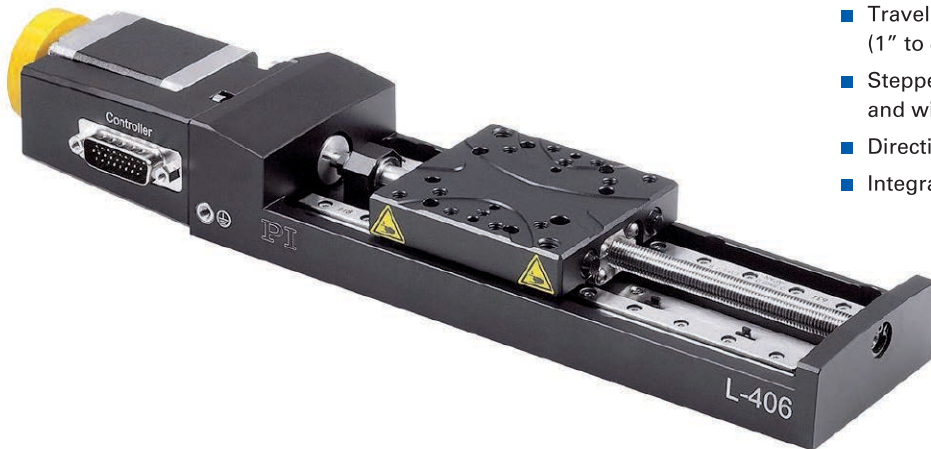

- Travel ranges from 26 mm to 102 mm (1" to 4")
- Stepper motor or DC servo motor with and without gearhead
- Direction-sensing reference point switch
- Integrated optical limit switches

Precision-class linear stage

The linear stage has a ground precision leadscrew that ensures smooth running. The combination of recirculating ball bearing and the stress-relieved aluminum base ensures good performance data.

Drive types

- .xxDD variant: DC servo motor for an average velocity up to 20 mm/s
- .xxDG variant: DC servo motor with gearhead for high torques and resolution at low motor power
- .xxSD variant: 2-phase stepper motor

Noncontact limit switches. Noncontact optical reference point switch with direction sensing in the middle of the travel range.

Position measurement

Integrated rotary encoder on the motor shaft (variants with DC servo motor).

Fields of application

Precision positioning in industry and research, inspection, micro-manipulation.

L-406 linear stages can be combined without adapter plate for multi-axis positioning on several axes.

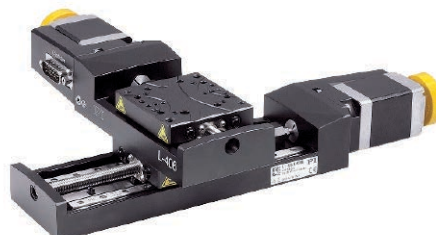

L-406 with DC motor

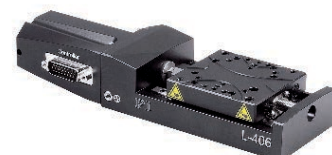

	L-406.10DD10 L-406.20DD10 L-406.40DD10	L-406.10DG10 L-406.20DG10 L-406.40DG10	L-406.10SD00 L-406.20SD00 L-406.40SD00	Unit	Tolerance
	Linear stage with DC motor and rotary encoder	Linear stage with DC gear motor and rotary encoder	Linear stage with stepper motor		
Active axis	X	X	X		
Motion and positioning					
Travel range*	26 / 52 / 102	26 / 52 / 102	26 / 52 / 102	mm	max.
Integrated sensor	Rotary encoder	Rotary encoder	–		
Sensor resolution rotary encoder	1024	512	–	cts./rev.	
Design resolution	0.244	0.0165	0.313**	µm	
Minimum incremental motion	0.5	0.2	0.2	µm	typ.
Unidirectional repeatability	0.5	0.5	0.5	µm	typ.
Backlash	±3	±3	±3	µm	typ.
Crosstalk, rotational (pitch, yaw)	±70 / ±90 / ±100	±70 / ±90 / ±100	±70 / ±90 / ±100	µrad	typ.
Linear crosstalk (straightness, flatness)	2 / 4 / 6	2 / 4 / 6	2 / 4 / 6	µm	
Max. velocity	20	3	20	mm/s	max.
Mechanical properties					
Load capacity	100	100	100	N	max.
Push/pull force	15	100	50	N	max.
Permissible lateral force	50	50	50	N	max.
Holding force	25	50	50	N	max.
Drive properties					
Spindle pitch	1	1	1	mm	
Gear ratio		2401:81	–		
Motor type	DC motor	DC gear motor	2-phase stepper motor		
Operating voltage	0 to ±24	0 to ±12	24	V	
Motor power	21	4	5.4	W	nominal
Reference and limit switches	Optical	Optical	Optical		
Miscellaneous					
Operating temperature range	–20 to 65	–20 to 65	–20 to 65	°C	
Material	Aluminum, steel	Aluminum, steel	Aluminum, steel		
Mass	0.9 / 0.9 / 1.1	0.89 / 0.9 / 1.09	0.99 / 1.1 / 1.19	kg	
Connector	HD Sub-D 26 (m)	HD Sub-D 26 (m)	HD Sub-D 26 (m)		
Recommended controller/driver	C-863 (single axis), C-884 (up to 4 axes)	C-863 (single axis), C-884 (up to 4 axes)	C-663.11 (single axis)		

Ask about custom designs!

All cables required for operation with the recommended controller are included in the scope of delivery. The cable length is 3 m. Cable for connecting to other controllers can be ordered as accessory.

* Travel ranges of the variants: L-406.1: 26 mm (1), L-406.2: 52 mm (2), L-406.4: 102 mm (4).

** 200 full steps/rev.

L-406 with DC gear motor, dimensions in mm

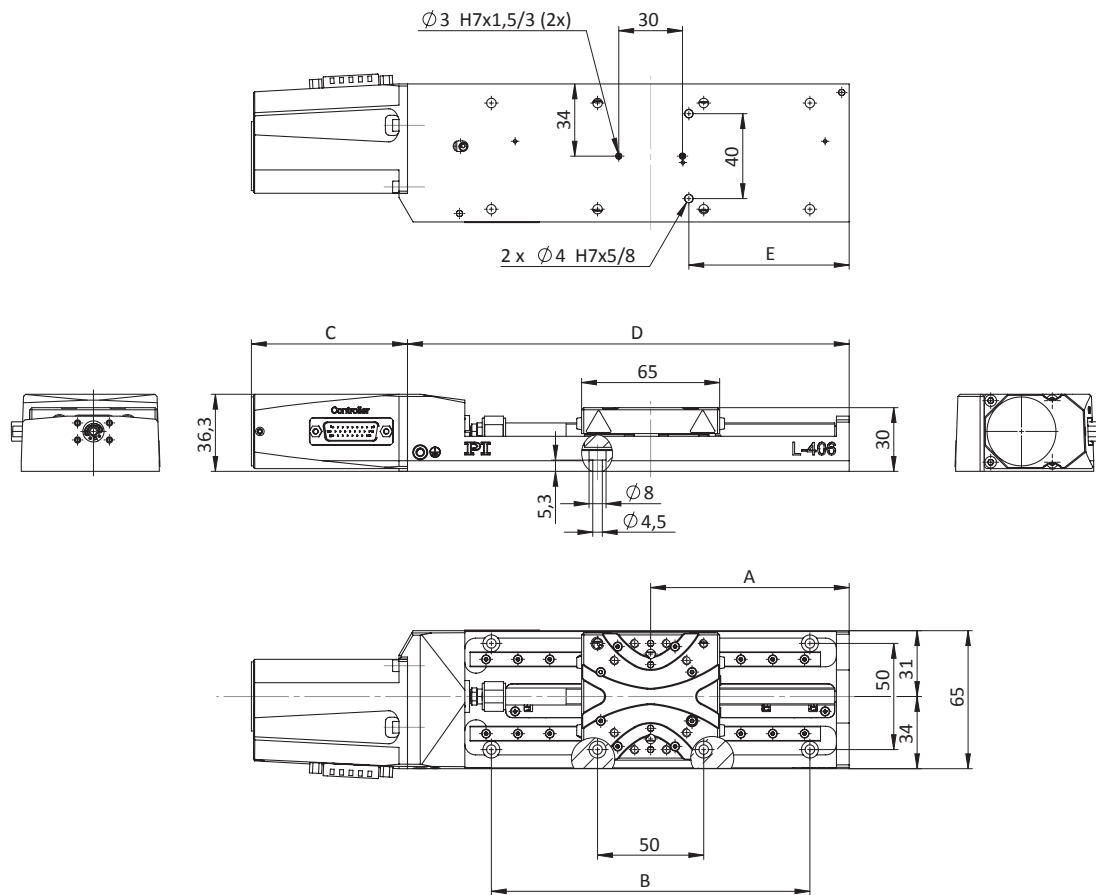

	A	B	C	D	E
L-406.10DG10	55,5	-	73,5	132	62,5
L-406.20DG10	68,5	100	73,5	158	75,5
L-406.40DG10	93,5	150	73,5	208	75,5

L-406 with stepper motor, dimensions in mm

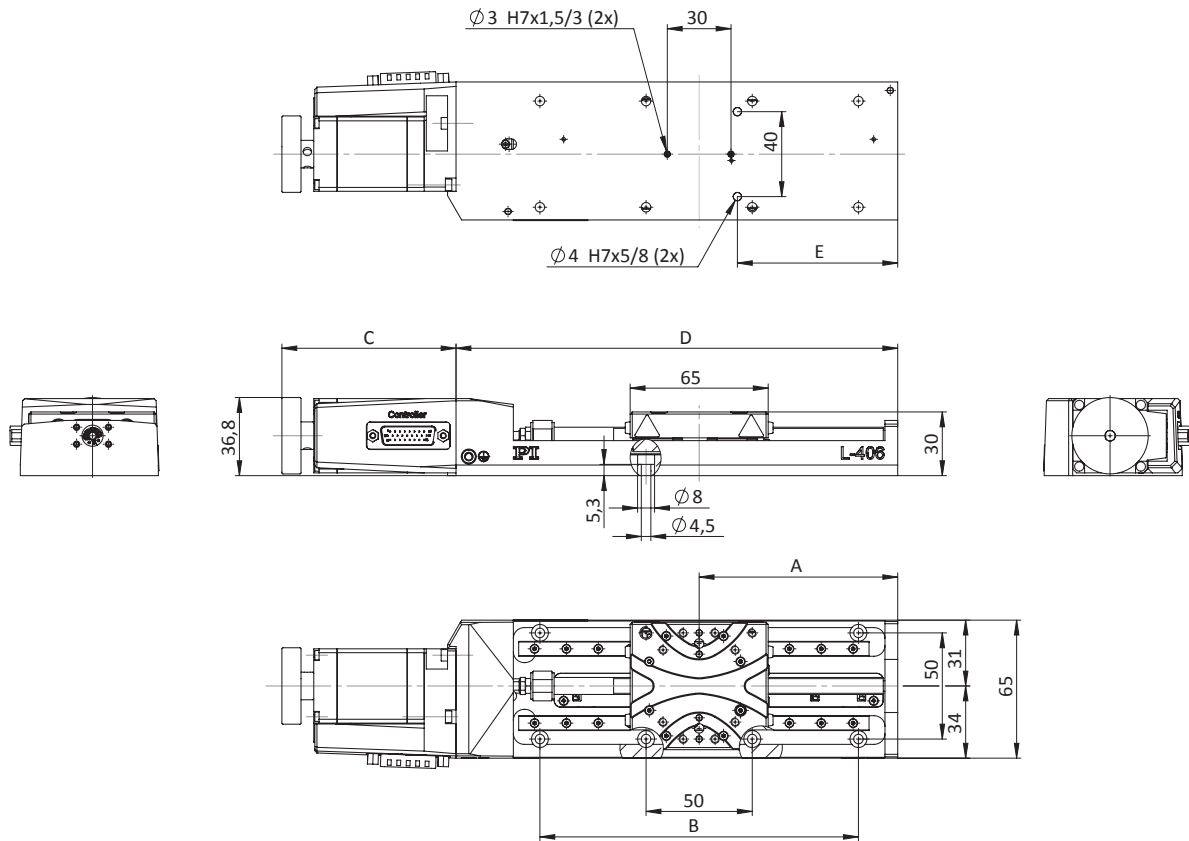

	A	B	C	D	E
L-406.10SD00	55,5	-	82	132	62,5
L-406.20SD00	68,5	100	82	158	75,5
L-406.40SD00	93,5	150	82	208	75,5

Detail drawing of the sled of the L-406, dimensions in mm

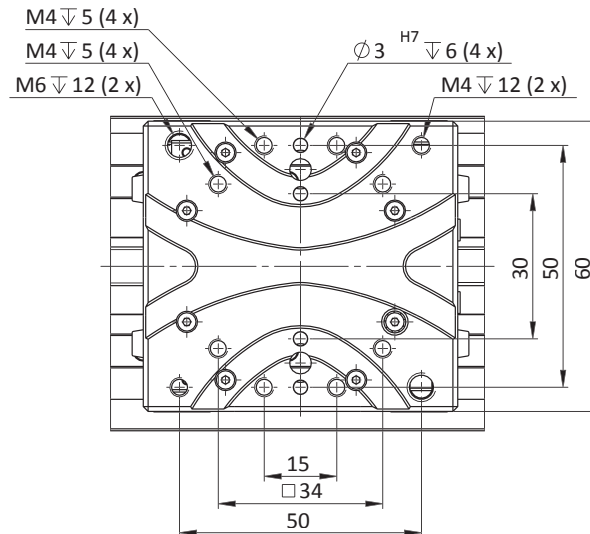

L-509 Precision Linear Stage

Compact Design, for Loads to 10 kg



- Travel ranges from 26 to 102 mm (1" to 4")
- Repeatability to 0.1 μm
- Optional with Direct Measuring Linear Encoder
- Efficient ActiveDrive DC servo motor, Stepper Motor or DC Gear Motor
- Direction-sensing reference point switch
- Integrated optical limit switches

Reference-class linear stage

High travel accuracy and load capacity due to crossed roller guides. Precision ball screw with 1 mm pitch. Compact design. Stress-relieved aluminum base for highest stability. Optical limit switches. Travel ranges of the variants: L-509.1: 26 mm (1"), L-509.2: 52 mm (2"), L-509.4: 102 mm (4").

Drive types

- .xxAD variant: ActiveDrive DC motor for high velocity: Control via pulse-width-modulated (PWM) signals, the operating voltage is attained via an amplifier integrated in the motor housing.
- xxDG variant: DC servo motor with gearhead for high torques and resolution at low motor power
- .xxSD variant: 2-phase stepper motor for low velocity and high resolution

Noncontact limit switches. Noncontact optical reference point switch with direction sensing in the middle of the travel range.

Position measurement

- Integrated rotary encoder on the motor shaft (variants with DC gear motor).
- Laterally mounted linear encoder. Direct position measurement of the motion platform without influence on the positioning precision by mechanical play or hysteresis in the drivetrain

Min. incremental motion and slow motion

In conjunction with the SMC Hydra controller, versions with stepper motor and integrated linear encoder (L-509.xASD00) achieve repeatable minimum incremental motion in the range of the sensor resolution. The same configuration attains constant low velocities of a few sensor increments per second.

Fields of application

Precision positioning in industry and research, high duty cycles.

L-511 and L-509 precision stages can be combined without adapter plate for multi-axis positioning on several axes

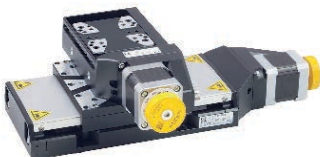

Multi-axis set-up with L-511 (horizontal) and L-509 (vertical) precision stages



	L-509.x4AD00	L-509.x0AD10	L-509.x0DG10	L-509.xASD00	L-509.x0SD00	Unit	Tolerance
	Linear stage with Active-Drive DC motor and linear encoder (direct position measurement)	Linear stage with Active-Drive DC motor and rotary encoder	Linear stage with DC gear motor and rotary encoder	Linear stage with stepper motor and linear encoder (direct position measurement)	Linear stage with stepper motor		
Motion and positioning							
Travel range*	26 / 52 / 102	26 / 52 / 102	26 / 52 / 102	26 / 52 / 102	26 / 52 / 102	mm	max.
Integrated sensor	Linear encoder	Rotary encoder	Rotary encoder	Linear encoder	–		
Sensor resolution rotary encoder	–	16384	4096	–	–	cts./rev.	
Design resolution	0.05	0.06	0.008	0.001**	0.315***	µm	typ.
Minimum incremental motion	0.2	0.8	0.1	0.01	0.315***	µm	typ.
Unidirectional repeatability	0.1	0.2	0.1	–	0.3	µm	typ.
Backlash	0.2	0.3	1		0.5	µm	typ.
Bidirectional repeatability	±0.3	±0.5		±0.2		µm	
Crosstalk, angular error xry (pitch)	±60 / ±90 / ±120	±60 / ±90 / ±120	±60 / ±90 / ±120	±60 / ±90 / ±120	±60 / ±90 / ±120	µrad	typ.
Crosstalk, angular error xrz (yaw)	±60 / ±90 / ±120	±60 / ±90 / ±120	±60 / ±90 / ±120	±60 / ±90 / ±120	±60 / ±90 / ±120	µrad	typ.
Max. velocity	50	50	3	20	20	mm/s	max.
Mechanical properties							
Spindle pitch	1	1	1	1	1	mm	
Gear ratio	–	–	2401:81	–	–		
Load capacity	100	100	100	100	100	N	max.
Push/pull force	60	60	60	60	60	N	max.
Permissible lateral force	50	50	50	50	50	N	max.
Holding force	15	15	60	60	60	N	max.
Drive properties							
Motor Type	DC motor with PWM control	DC motor with PWM control	DC gear motor	2-phase stepper motor	2-phase stepper motor		
Operating voltage	24	24	0 to ±12	24	24	V	
Motor power	80	80	8.5			W	nominal
Reference and limit switches	Optical	Optical	Optical	Optical	Optical		
Miscellaneous							
Operating temperature range	0 to 55	–20 to 65	–20 to 65	0 to 55	–20 to 65	°C	
Material	Aluminum, steel	Aluminum, steel	Aluminum, steel	Aluminum, steel	Aluminum, steel		
Mass	1.4 / 1.6 / 1.9	1.4 / 1.6 / 1.9	1.4 / 1.6 / 1.9	1.4 / 1.6 / 1.9	1.4 / 1.6 / 1.9	kg	
Connector	Sub-D 15 (Motor and Encoder), 3 m cable incl.	Sub-D 15 (Motor and Encoder), 3 m cable incl.	HD Sub-D 26 (motor and rotary encoder) to Sub-D 15, incl. 3 m cable	HD Sub-D 26 (motor), Sub-D 9 (linear encoder), 3 m cable set incl.	HD Sub-D 26 (motor) to Sub-D 15, 3 m cable incl.		
Recommended controller/driver	C-863 (single-axis) C-884 (up to 4 axes)	C-863 (single-axis) C-884 (up to 4 axes)	C-863 (single-axis), C-884 (up to 4 axes)	SMC Hydra (double-axis)	C-663.11 (single axis)		

All cables required for operation with the recommended controller are included in the scope of delivery. Cables for connecting to other controllers can be ordered as accessory.

* Travel ranges of the variants: L-509.1: 26 mm (1), L-509.2: 52 mm (2), L-509.4: 102 mm (4).

** Sin/cos analog signals with 1 V_{pp}, operation with SMC Hydra controller with maximum interpolation.

*** 200 full steps/rev., max. 1.2 A/phase. Motor resolution with C-663 stepper motor controller.

Ask about custom designs!

L-509 versions with DC gear motor, dimensions in mm

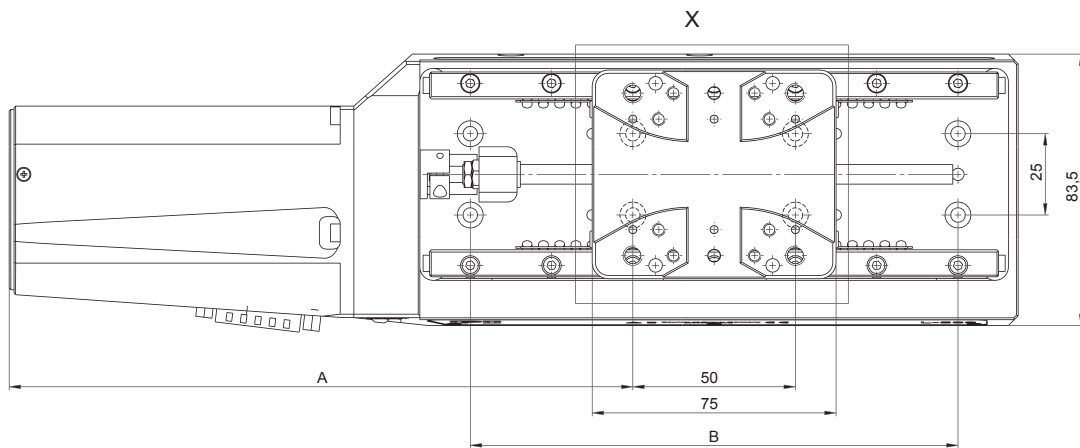
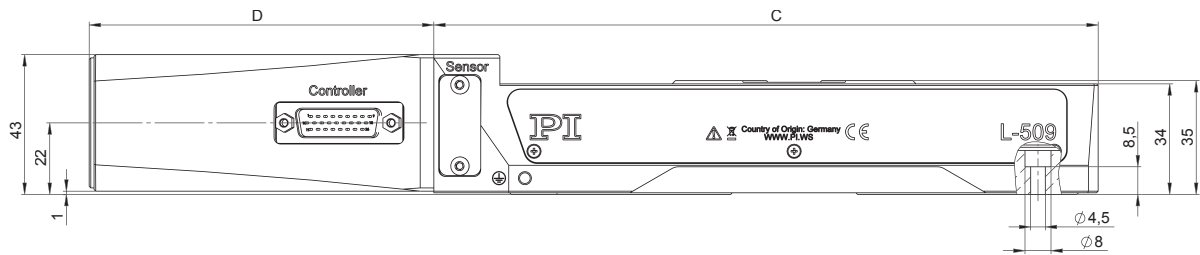

	A	B	C	D
L-509.10DG10	157,3	100	135,3	106
L-509.20DG10	166,8	100	154,3	106
L-509.40DG10	191,8	150	204,3	106

L-509 versions with stepper motor, dimensions in mm

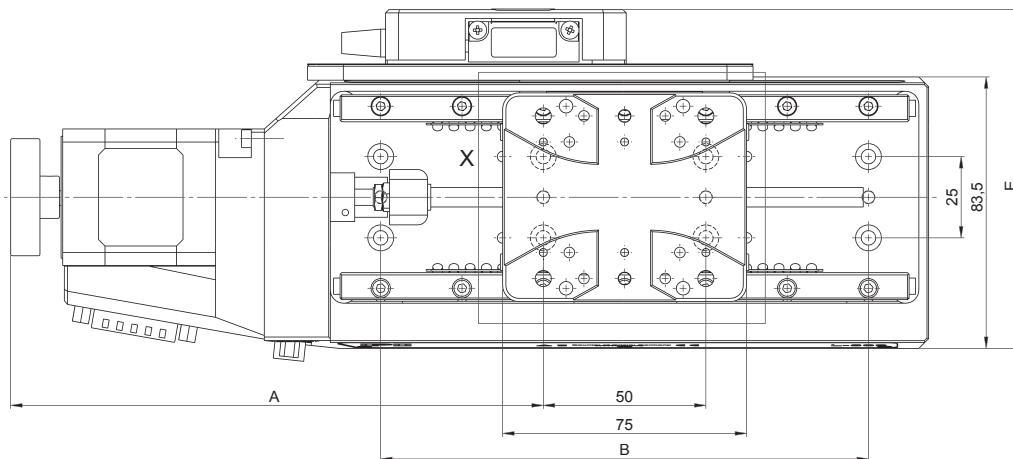
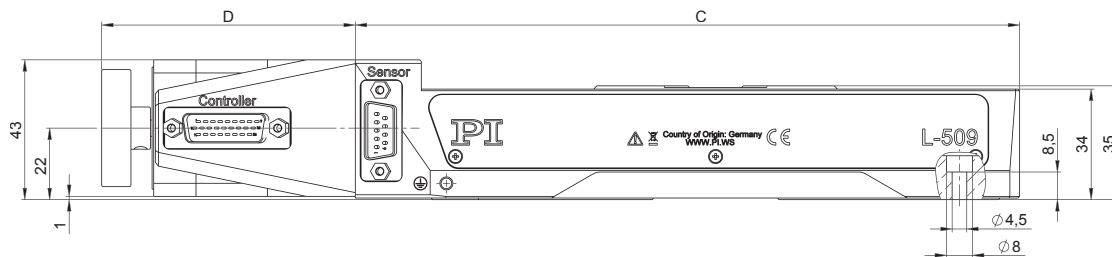

	A	B	C	D	E
L-509.10SD00	129,3	100	135,3	78	-
L-509.1ASD00	129,3	100	135,3	78	104,2
L-509.20SD00	138,8	100	154,3	78	-
L-509.2ASD00	138,8	100	154,3	78	104,2
L-509.40SD00	163,8	150	204,3	78	-
L-509.4ASD00	163,8	150	204,3	78	104,2

L-509 versions with ActiveDrive DC motor, dimensions in mm

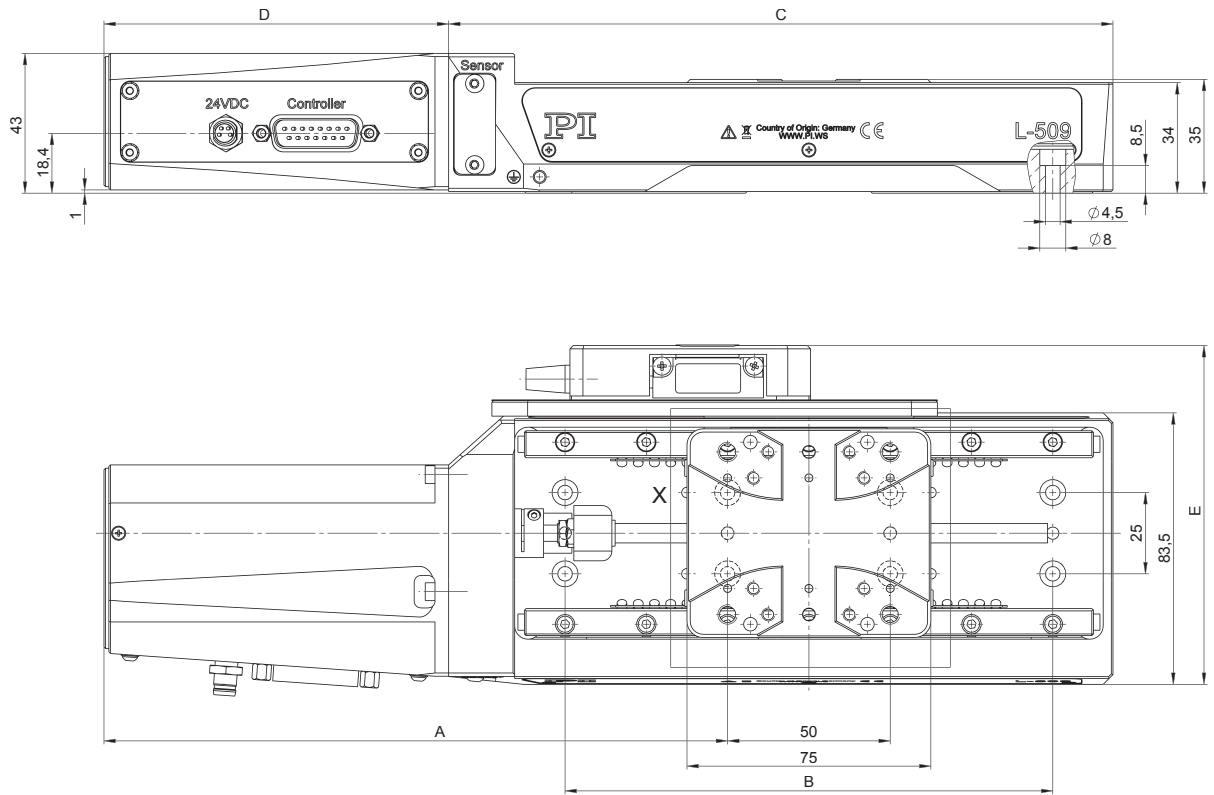

	A	B	C	D	E
L-509.10AD10	157,3	100	135,3	106	-
L-509.14AD00	157,3	100	135,3	106	104,2
L-509.20AD10	166,8	100	154,3	106	-
L-509.24AD00	166,8	100	154,3	106	104,2
L-509.40AD10	191,8	150	204,3	106	-
L-509.44AD00	191,8	150	204,3	106	104,2

Detail drawing of the sled of the L-509

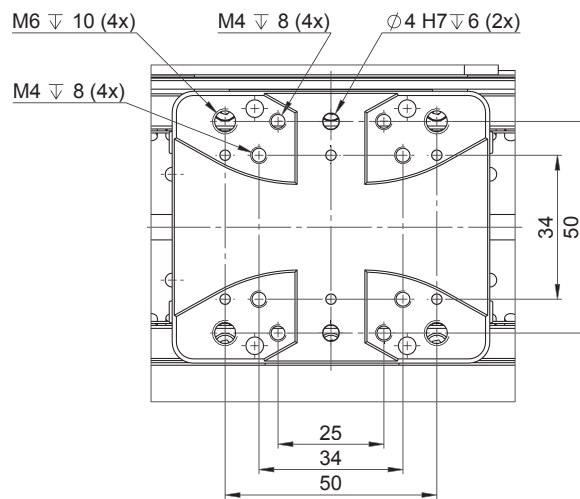

Direction of the axes and torques for linear stages

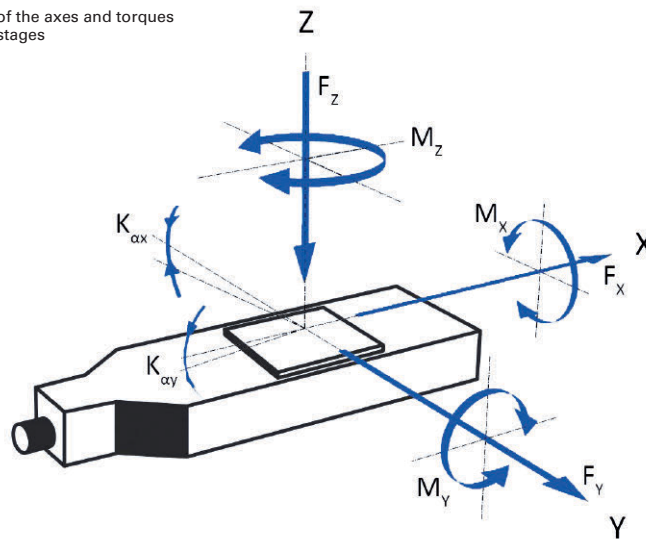

L-511 High-Precision Linear Stage

High Travel Accuracy



- Travel ranges to 155 mm (6")
- Optional linear encoder for direct position measurement
- Efficient ActiveDrive DC servo motor, Stepper Motor or DC Gear Motor
- Direction-sensing reference point switch

Reference-class linear stage

Recirculating ball bearings for high travel accuracy and load capacity. Precision ball screw with 2 mm pitch. Stress-relieved aluminum base for highest stability. Travel range of the variants: L-511.2: 52 mm (2), L-511.4: 102 mm (4), L-511.6: 155 mm (6).

Drive types

- .xxAD variant: ActiveDrive DC motor for high velocity: Control via pulse-width-modulated (PWM) signals, the operating voltage is attained via an amplifier integrated in the motor housing.
- .xxDG variant: DC servo motor with gearhead for high torques and resolution at low motor power
- .xxSD variant: 2-phase stepper motor for low velocity and high resolution

Noncontact limit switches. Noncontact optical reference point switch with direction sensing in the middle of the travel range.

Position measurement

- Integrated rotary encoder on the motor shaft (variants with DC gear motor)
- Integrated linear encoder, centrally installed. Direct position measurement of the motion platform without influence on the positioning precision by mechanical play or hysteresis in the drivetrain

Minimum incremental motion and slow motion

In conjunction with the SMC Hydra controller, versions with stepper motor and integrated linear encoder (L-511.xASD00) achieve repeatable minimum incremental motion in the range of the sensor resolution. The same configuration attains constant low velocities of a few sensor increments per second.

Fields of application

Precision positioning in industry and research, high duty cycles.

L-511 and L-509 precision stages can be combined without adapter plate for multi-axis positioning on several axes

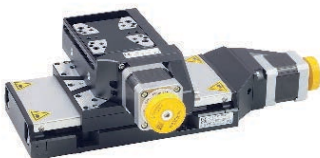

Multi-axis set-up with L-511 (horizontal) and L-509 (vertical) precision stages



	L-511.x4AD00	L-511.x0AD10	L-511.x0DG10	L-511.xASD00	L-511.x0SD00	Unit	Tolerance
	Linear stage with Active-Drive DC motor and linear encoder (direct position measurement)	Linear stage with Active-Drive DC motor and rotary encoder	Linear stage with DC gear motor and rotary encoder	Linear stage with stepper motor and linear encoder (direct position measurement)	Linear stage with stepper motor		
Motion axes	X	X	X	X	X		
Motion and positioning							
Travel range*	52 / 102 / 155	52 / 102 / 155	52 / 102 / 155	52 / 102 / 155	52 / 102 / 155	mm	
Integrated sensor	Linear encoder	Rotary encoder	Rotary encoder	Linear encoder	–		
Sensor resolution rotary encoder	–	16384	4096	–	–	cts./rev.	
Design resolution	0.06	0.06	0.0164	0.001**	0.625***	µm	
Minimum incremental motion	0.15	0.4	0.1	0.2	0.625***	µm	typ.
Unidirectional repeatability	0.1	0.2	0.2	0.1	0.6	µm	typ.
Backlash	0.2	0.3	1		1	µm	typ.
Bidirectional repeatability	±0.2	±1.25		±0.2		µm	typ.
Crosstalk, angular error xry (pitch)	±40 / ±60 / ±70	±40 / ±60 / ±70	±40 / ±60 / ±70	±40 / ±60 / ±70	±40 / ±60 / ±70	µrad	
Crosstalk, angular error xrz (yaw)	±40	±40	±40	±40	±40	µrad	
Max. velocity	90	90	6	45	45	mm/s	
Mechanical properties							
Spindle pitch	2	2	2	2	2	mm	
Gear ratio	–	–	2401:81	–	–		
Load capacity	500	500	500	500	500	N	max.
Push/pull force	100	100	100	100	100	N	max.
Permissible lateral force	250	250	250	250	250	N	max.
Holding force	10	10	20	40	40	N	max.
Drive properties							
Motor Type	DC motor with PWM control	DC motor with PWM control	DC gear motor	2-phase stepper motor	2-phase stepper motor		
Operating voltage	24 (PWM)	24 (PWM)	0 to ±12	24	24	V	
Motor power	80	80	8.5			W	nomial
Reference and limit switches	Optical	Optical	Optical	Optical	Optical		
Miscellaneous							
Operating temperature range	0 to 55	–20 to 65	–20 to 65	0 to 55	–20 to 65	°C	
Material	Aluminum, steel	Aluminum, steel	Aluminum, steel	Aluminum, steel	Aluminum, steel		
Mass	2.5 / 2.9 / 3.3	2.5 / 2.9 / 3.3	2.3 / 2.7 / 3.1	2.5 / 2.9 / 3.3	2.5 / 2.9 / 3.3	kg	±5 %
Connector	Sub-D 15 (Motor and Encoder), 3 m cable incl.	Sub-D 15 (Motor and Encoder), 3 m cable incl.	HD Sub-D 26 (motor and rotary encoder), 3 m cable incl. (HD Sub-D 26 to Sub-D 15)	HD Sub-D 26 (motor), Sub-D 9 (linear encoder), 3 m cable set incl.	HD Sub-D 26 (motor), 3 m cable incl. (HD Sub-D 26 to Sub-D 15)		
Recommended controllers	C-863 (single axis) C-884 (up to 4 axes)	C-863 (single axis) C-884 (up to 4 axes)	C-863 (single axis) C-884 (up to 4 axes)	SMC Hydra motion controller (double axis)	C-663 (single axis)		

* Travel range of the variants: L-511.2: 52 mm (2), L-511.4: 102 mm (4), L-511.6: 155 mm (6).

** Sin/cos analog signals with 1 V_{pp}, operation with SMC Hydra controller with maximum interpolation.

*** 200 full steps/rev., max. 1.2 A/phase.

All cables required for operation with the recommended controller are included in the scope of delivery. Ask about custom designs!

L-511 versions with DC gear motor, dimensions in mm

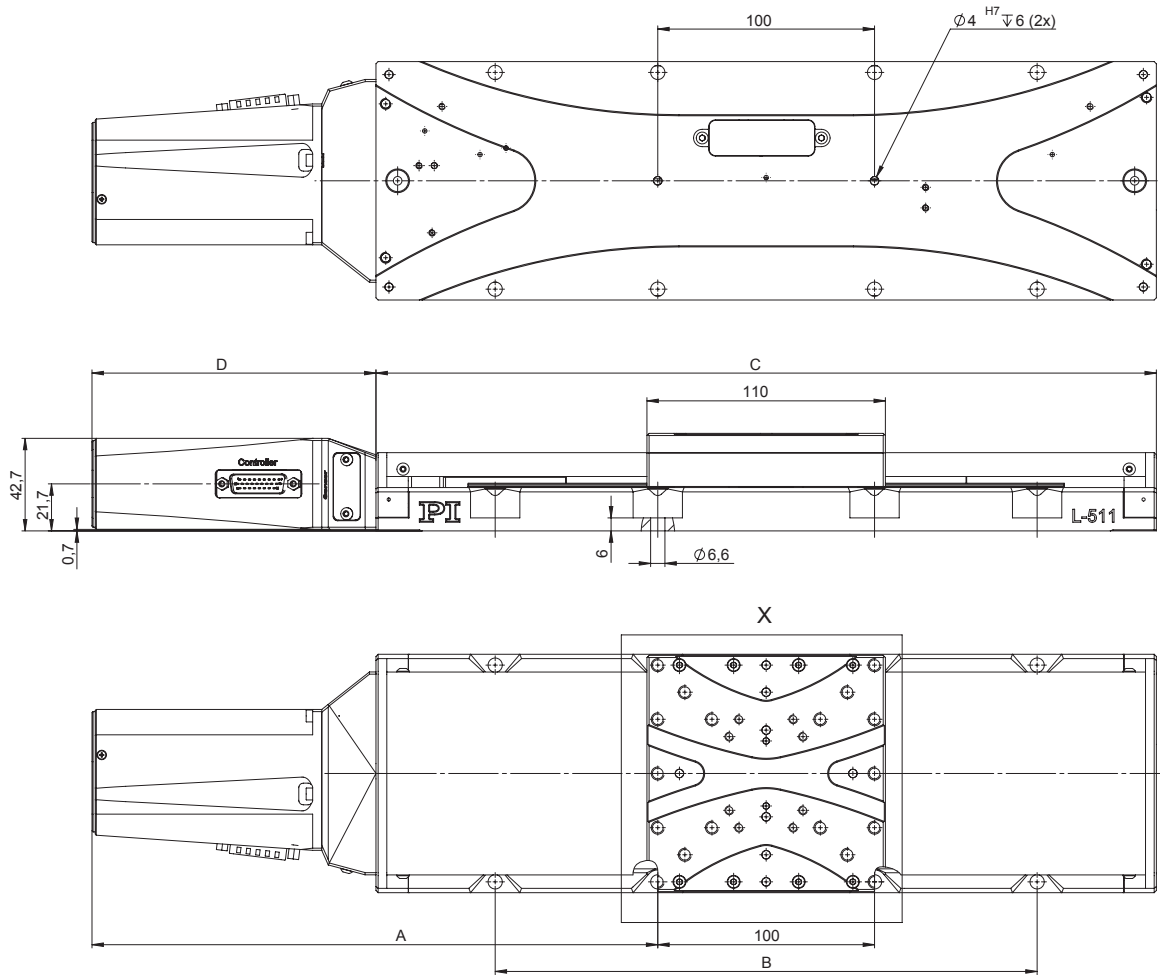

	A	B	C	D
L-511.20DG10	186	-	210	131
L-511.40DG10	211	-	260	131
L-511.60DG10	261	250	360	131

L-511 versions with stepper motor, dimensions in mm

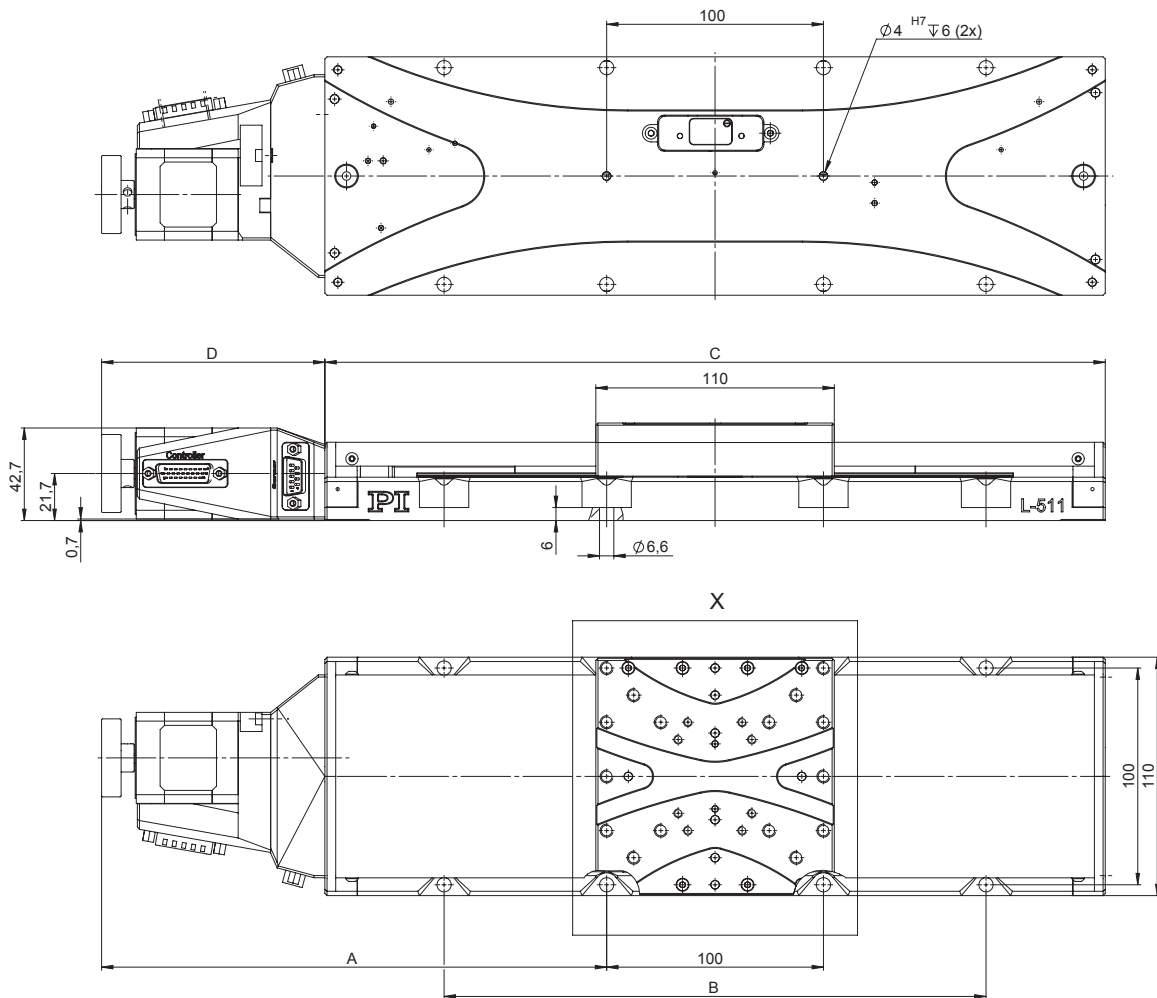

	A	B	C	D
L-511.20SD00	158	-	210	103
L-511.2ASD00	158	-	210	103
L-511.40SD00	183	-	260	103
L-511.4ASD00	183	-	260	103
L-511.60SD00	233	250	360	103
L-511.6ASD00	233	250	360	103

L-511 versions with ActiveDrive DC motor, dimensions in mm

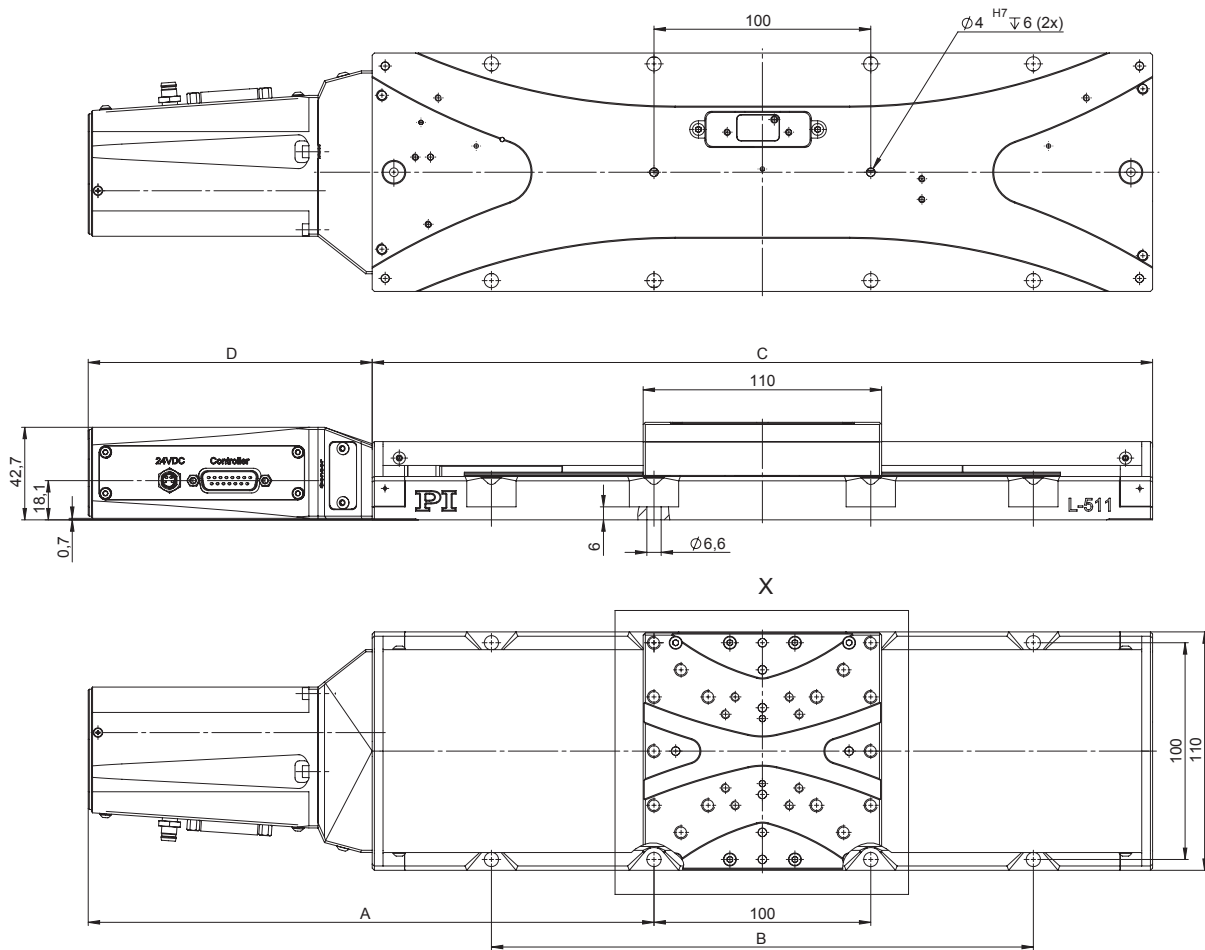

	A	B	C	D
L-511.20AD10	186	-	210	131
L-511.24AD00	186	-	210	131
L-511.40AD10	211	-	260	131
L-511.44AD00	211	-	260	131
L-511.60AD10	261	250	360	131
L-511.64AD00	261	250	360	131

Detail drawing of the sled of the L-511

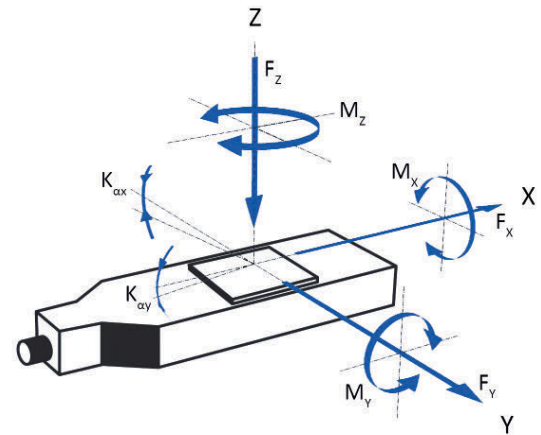
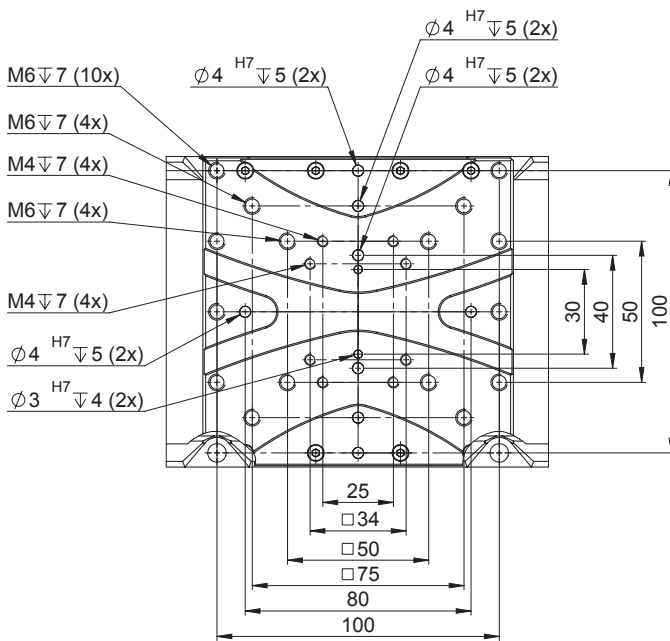

Direction of the axes and torques for linear stages

The L-511 reliably performs repeatable 20-nm steps with the linear encoder and SMC Hydra motion controller

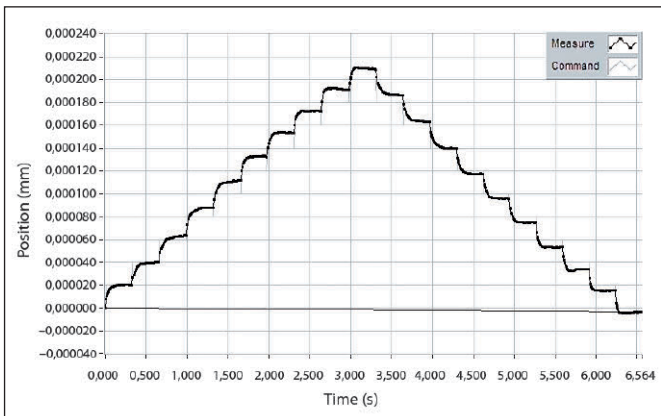

L-611 Precision Rotation Stage

High Travel Accuracy



- Unlimited travel range
- Ultrahigh resolution
- Maximum velocity 200°/s
- Direction-sensing reference point switch

Reference-class rotation stage

High-precision positioning due to low-play preloaded worm gear. Preloaded pivot bearings for high travel accuracy. Clear aperture with \varnothing 35 mm. Unlimited travel range in both directions of rotation. Noncontact reference point switch. Compact multi-axis positioning systems with L-511 linear stages and L-310 Z stages possible. Vacuum versions available on request.

Versions

- Low-vibration stepper motor
- DC motor with ActiveDrive
- Additional high-resolution optical angle measuring system

Option: Measurement of the travel accuracy and positioning accuracy

Individual measurement logs for wobble, axial, and radial creep available on request. Please specify when ordering.

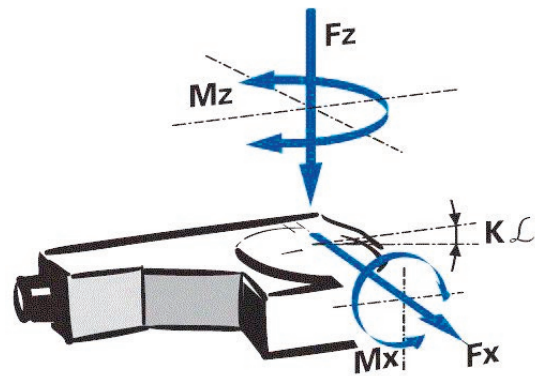

Direction of the axes and torques for rotation stages

	L-611.90SD	L-611.9ASD	L-611.90AD	L-611.94AD	Unit	Tolerance
		With integrated angle measuring system		With integrated angle measuring system		
Active axes	θ_z	θ_z	θ_z	θ_z		
Motion and positioning						
Rotation range	>360	>360	>360	>360	°	
Integrated sensor	–	Angle measuring system	Rotary encoder	Angle measuring system		
Design resolution	21.8 (0.00125)* 0.17 (0.00001)**	0.35 (0.00002)	3.5 (0.0002)	0.035 (0.000002)	μrad (°)	
Minimum incremental motion	43.6 (0.0025)* 0.34 (0.00002)**	0.7 (0.00004)	35 (0.002)	0.7 (0.00004)	μrad (°)	typ.
Backlash	350 (0.02)	–	350 (0.02)	–	μrad (°)	typ.
Unidirectional repeatability	35 (0.002)	3.5 (0.0002)	35 (0.002)	3.5 (0.0002)	μrad (°)	typ.
Bidirectional repeatability	–	± 3.5 (± 0.0002)	± 175 (± 0.01)	± 3.5 (± 0.0002)	μrad (°)	
Wobble (bearings)	± 15	± 15	± 15	± 15	μrad	
Flatness (bearings)	± 1	± 1	± 1	± 1	μm	
Eccentricity (bearings)	± 2.5	± 2.5	± 2.5	± 2.5	μm	
Velocity	50	50	200	200	°/s	max.
Mechanical properties						
Worm gear ratio	90:1	90:1	90:1	90:1		
Motor resolution	200	200	–	–	Full steps/rev ev.	
Load capacity / axial force	100	100	100	100	N	max.
Permissible torque M_x in θ_x, θ_y	40	40	40	40	Nm	max.
Permissible torque M_z in θ_z	3	3	3	3	Nm	max.
Tip/tilt stiffness of the platform k_t	30	30	30	30	$\mu\text{rad}/\text{Nm}$	
Drive properties						
Motor Type	2-phase stepper motor***	2-phase stepper motor***	DC motor with PWM control	DC motor with PWM control		
Reference point switch	Hall effect	Hall effect	Hall effect	Hall effect		
Miscellaneous						
Material	Aluminum, black anodized, stainless steel, red bronze	Aluminum, black anodized, stainless steel, red bronze	Aluminum, black anodized, stainless steel, red bronze	Aluminum, black anodized, stainless steel, red bronze		
Mass	2.6	2.6	2.6	2.6	kg	
Recommended controllers / drivers	C-663.11 C-663.12 (single axis)	SMC Hydra (double axis)	C-863	C-863		

* with C-663.11 Mercury Step Controller

** with C-663.12 Mercury Step Controller

*** 200 full steps/rev., max. 1.2 A/phase

Specifications for vacuum versions can differ.

L-611.90SD rotation stage, dimensions in mm

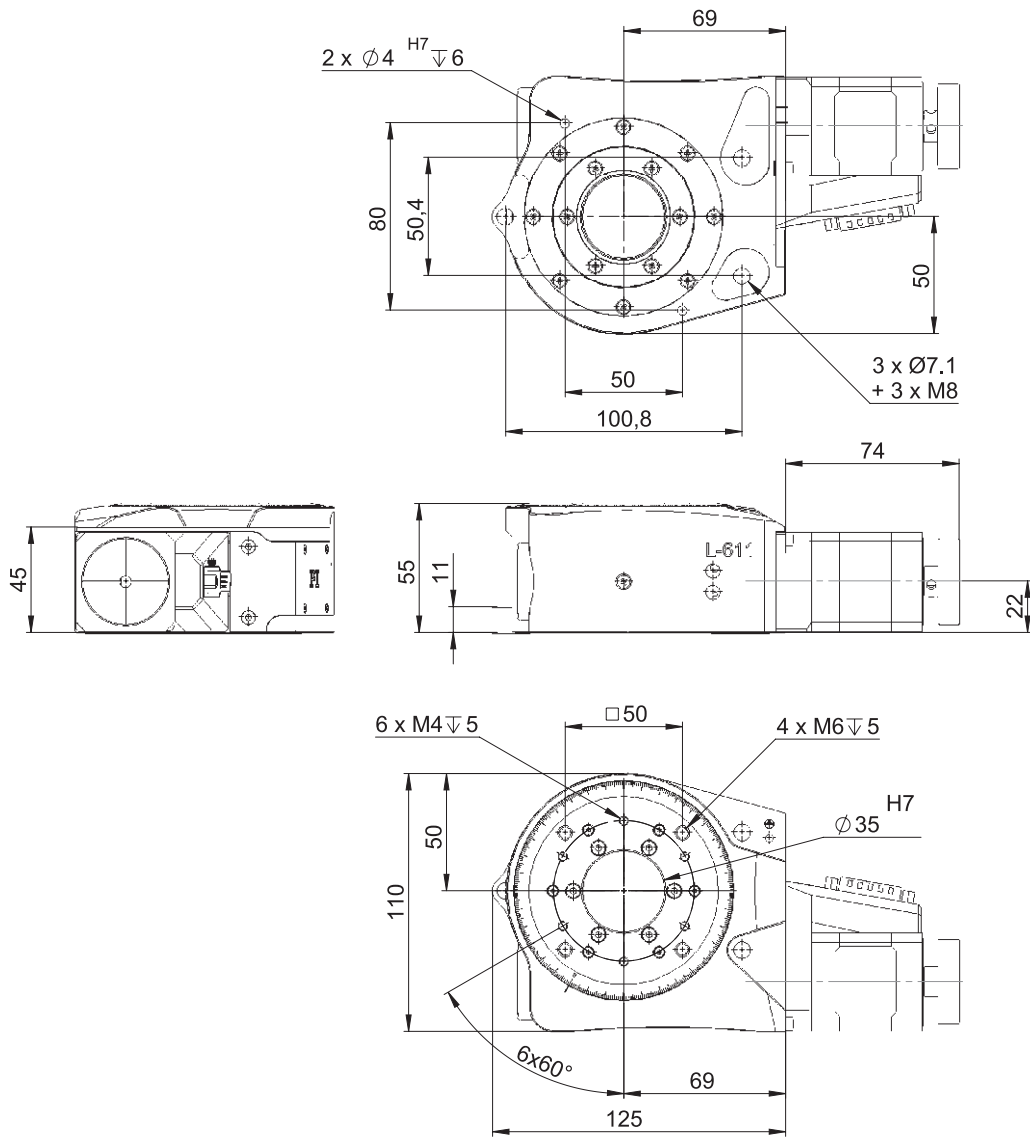

L-611.9ASD rotation stage, dimensions in mm

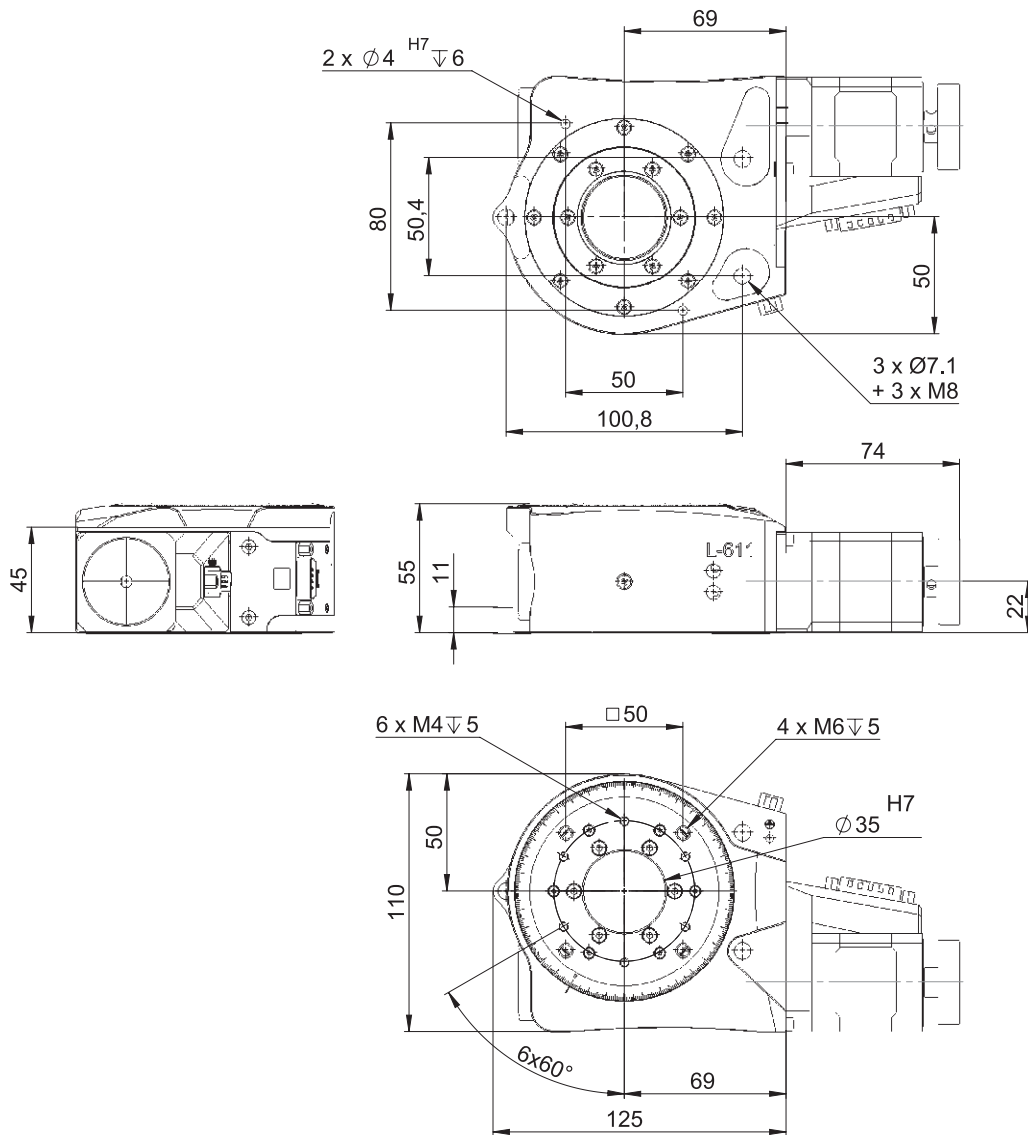

L-611.90AD and L-611.94AD rotation stages, dimensions in mm

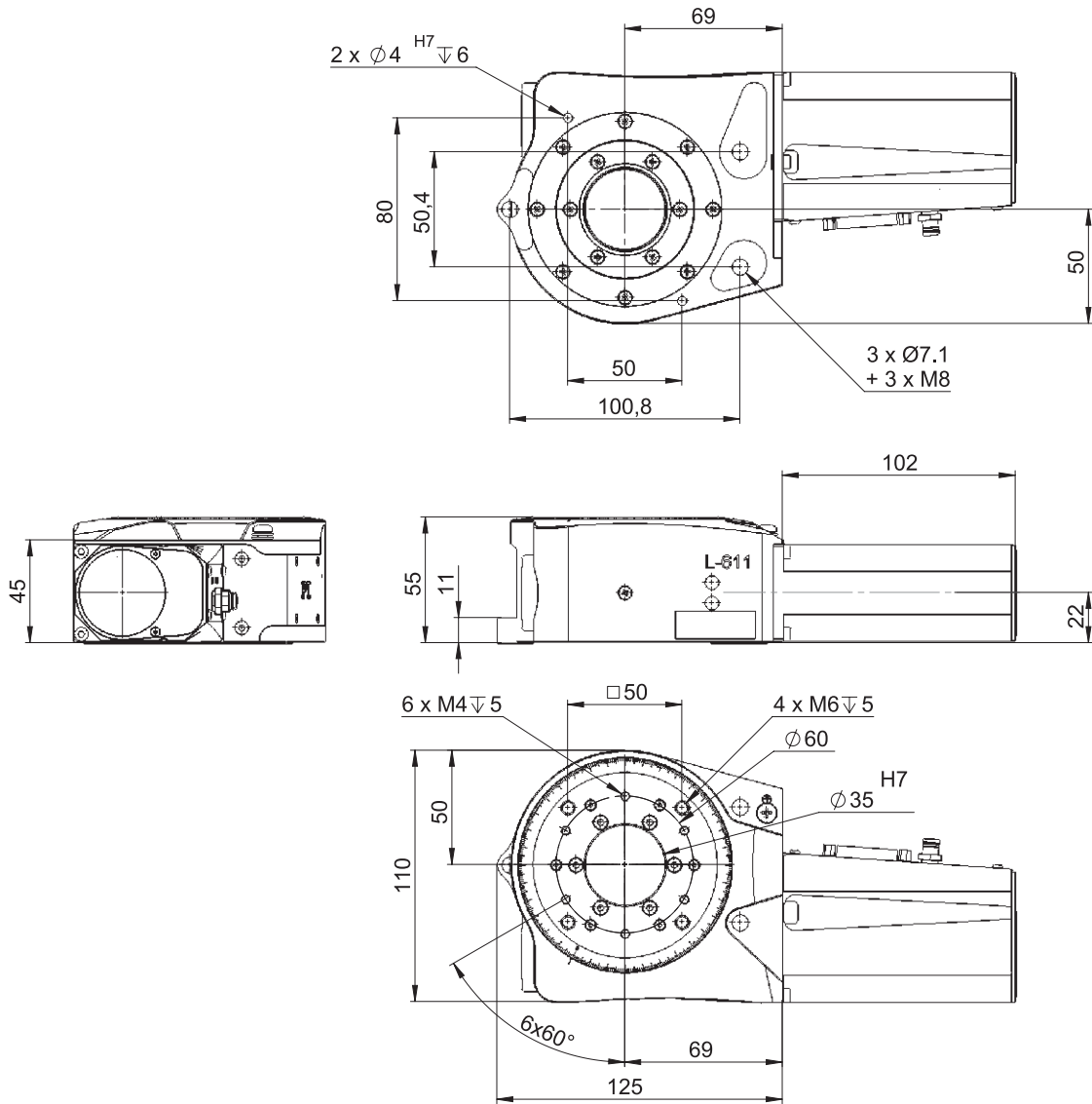

L-731 Precision XY stage

High Travel Accuracy and Stability



- Travel range 205 mm × 205 mm (8")
- Unidirectional repeatability to 0.1 μm
- Velocity to 90 mm/s
- 2-phase stepper motors or DC motors
- Incremental encoder with 10 nm resolution
- Rotary encoder with 20000 impulses/revolutions

Direct position measurement with incremental encoder

Noncontact optical encoders measure the actual position directly at the motion platform with the greatest accuracy so that non-linearity, mechanical play or elastic deformation have no influence on position measuring. Optical limit and reference point switches.

Crossed roller bearings

With crossed roller bearings, the point contact of the balls in ball bearings is replaced by a line contact of the hardened rollers. Consequently, they are considerably stiffer and need less preload, which reduces friction and allows smoother running. Crossed roller bearings are also distinguished by high guiding accuracy and load capacity. Force-guided rolling element cages prevent linear guide creeping.

Drive types

- 2-phase stepper motor for high torque even at low velocities and higher resolution
- DC motor for high velocity constancy, low vibration, and high velocities

Other travel ranges on request.

Application fields

Industry and research. Metrology, inspection, industrial microscopy

Stages with stepper motor	L-731.40SD	L-731.44SD	L-731.4ASD	Unit	Tolerance
	XY stage with stepper motor	XY stage with stepper motor and linear encoder (direct position measurement)	XY stage with stepper motor and linear encoder (direct position measurement)		
Motion and positioning					
Active axes	X, Y	X, Y	X, Y		
Travel range	205 × 205	205 × 205	205 × 205	mm	
Integrated sensor	–	Incremental linear encoder with A/B quadrature signal transmission	Incremental linear encoder with sin/cos signal transmission		
Sensor resolution	–	10	10*	nm	
Sensor signal period	–	–	20	µm	
Minimum incremental motion	1.25**	0.05	0.05	µm	typ.
Unidirectional repeatability	0.5**	0.1	0.1	µm	typ.
Bidirectional repeatability	±5**	±0.5	±0.5	µm	typ.
Backlash	3	–	–	µm	
Pitch	±75	±75	±75	µrad	typ.
Yaw	±75	±75	±75	µrad	typ.
Straightness / flatness	±3	±3	±3	µm	typ.
Velocity	45	45	45	mm/s	max.
Reference and limit switches	optical	optical	optical		
Mechanical properties					
Load capacity	50	50	50	N	
Permissible torque in θ_x, θ_y	125	125	125	N·m	
Permissible torque in θ_z	125	125	125	N·m	
Moved mass in X	12	12	12	kg	
Moved mass in Y	3.5	3.5	3.5	kg	
Overall mass	15.5	15.5	15.5	kg	
Guiding	Crossed roller guide with anti-creep system	Crossed roller guide with anti-creep system	Crossed roller guide with anti-creep system		
Drive properties					
Motor Type	2-phase stepper motor	2-phase stepper motor	2-phase stepper motor		
Spindle pitch	2	2	2	mm	
Operating voltage	24 – 48	24 – 48	24 – 48	V	
Motor power	5	5	5	W	nominal
Miscellaneous					
Operating temperature range	10 to 50	10 to 50	10 to 50	°C	
Humidity	20 to –90 % rel., not condensing	20 to –90 % rel., not condensing	20 to –90 % rel., not condensing		
Material	Aluminum, black anodized	Aluminum, black anodized	Aluminum, black anodized		
Connection	Motor connection: 2 × HD Sub-D 26 (m)	Motor and sensor connection: 2 × HD Sub-D 26 (m)	Motor connection: 2 × HD Sub-D 26 (m) Sensor connection: 2 × Sub-D 15 (f)		
Recommended controller	2 × C-663 Mercury Step Motion Controller, SMC Hydra Motion Controller for 2 axes C-885 PIMotionMaster for multi-axis controller systems	2 × C-663 Mercury Step motion controller C-885 PIMotionMaster for multi-axis controller systems	SMC Hydra Motion Controller for 2 axes		

* with SMC Hydra. Other interpolation factors are available as an option.

** with C-663 Mercury Step.

All cables required for operation with the recommended controller are included in the scope of delivery. Cable for connecting to other controllers can be ordered as accessory.

Stages with DC motor	L-731.093132	L-731.093112	L-731.093111	Unit	Tolerance
	XY stage with DC motor and rotary encoder	XY stage with DC motor and linear encoder (direct position measurement)	XY stage with DC motor and linear encoder (direct position measurement)		
Motion and positioning					
Active axes	X,Y	X,Y	X,Y		
Travel range	205 × 205	205 × 205	205 × 205	mm	
Integrated sensor	Rotary encoder	Incremental linear encoder with A/B quadrature signal transmission	Incremental linear encoder with sin/cos signal transmission		
Sensor resolution		10	10*	nm	
Sensor resolution	20000	–	–	Cts./rev.	
Sensor signal period	–	–	20	µm	
Minimum incremental motion	0.8	1	0.1	µm	typ.
Unidirectional repeatability	0.5	0.2	0.1	µm	typ.
Bidirectional repeatability	±5	±0.5	±0.5	µm	typ.
Backlash	3	–	–	µm	
Pitch	±75	±75	±75	µrad	typ.
Yaw	±75	±75	±75	µrad	typ.
Straightness / flatness	±3	±3	±3	µm	typ.
Velocity	90	50	50	mm/s	max.
Reference and limit switches	optical	optical	optical		
Mechanical properties					
Load capacity	50	50	50	N	
Permissible torque in θ_x, θ_y	125	125	125	N·m	
Permissible torque in θ_z	125	125	125	N·m	
Moved mass in X	12	12	12	kg	
Moved mass in Y	3.5	3.5	3.5	kg	
Overall mass	16	16	16	kg	
Guiding	Crossed roller guide with anti-creep system	Crossed roller guide with anti-creep system	Crossed roller guide with anti-creep system		
Drive properties					
Motor Type	DC motor	DC motor	DC motor		
Spindle pitch	2	2	2	mm	
Operating voltage	24	24	24	V	
Motor power	5	5	5	W	nominal
Miscellaneous					
Operating temperature range	10 to 50	10 to 50	10 to 50	°C	
Humidity	20 to –90 % rel., not condensing	20 to –90 % rel., not condensing	20 to –90 % rel., not condensing		
Material	Aluminum, black anodized	Aluminum, black anodized	Aluminum, black anodized		
Connection	Motor connection: 2 × HD Sub-D 26 (m)	Motor and sensor connection: 2 × HD Sub-D 26 (m)	Motor connection: 2 × HD Sub-D 26 (m) Sensor connection: 2 × Sub-D 15 (f)		
Recommended controller	2 × C-863 Mercury motion controller, SMC Hydra motion controller for 2 axes C-885 PIMotionMaster for multi-axis controller systems C-884 four-channel motion controller	2 × C-863 Mercury motion controller, SMC Hydra motion controller for 2 axes C-885 PIMotionMaster for multi-axis controller systems C-884 four-channel motion controller	SMC Hydra Motion Controller for 2 axes		

* with SMC Hydra. Other interpolation factors are available as an option.
All cables required for operation with the recommended controller are included in the scope of delivery.
Cable for connecting to other controllers can be ordered as accessory.

L-731, dimensions in mm

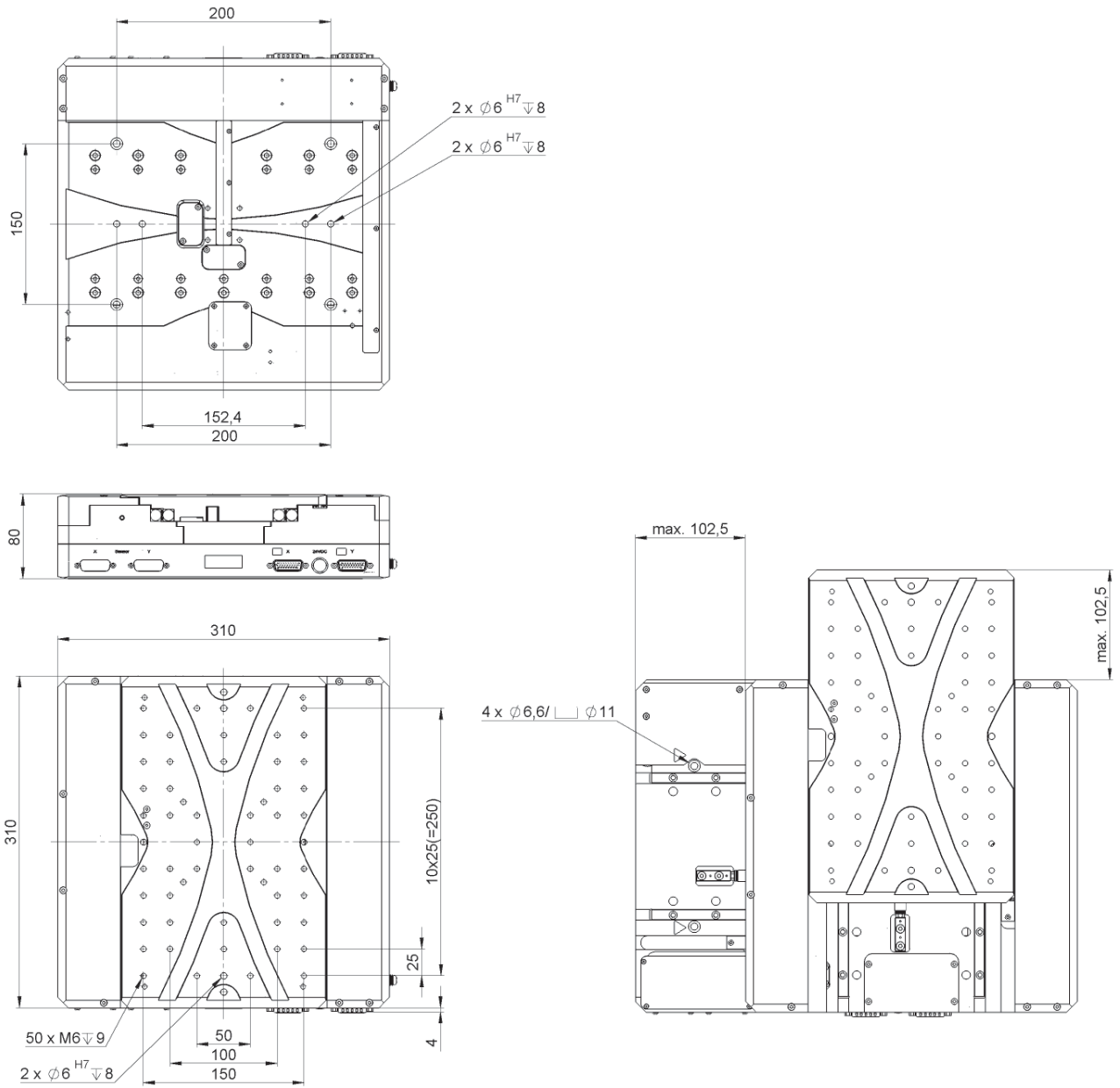

C-663.12

Mercury Step Stepper Motor Controller, 1 Axis

For Closed-Loop and Open-Loop Operation, HD Sub-D 26, 48 V



- High microstep resolution
- Operating voltage up to 48 V
- Open-loop and closed-loop operation of 2-phase stepper motors
- Support for external sensors
- Daisy chain networking

Mercury Step controller for 2-phase stepper motors

1 Axis. Microstep resolution: 1/2048 full step. Open-loop and closed-loop operation. Point-to-point motion, trapezoidal velocity profile. Networkable via daisy chain.

Encoder inputs

Differential signal transmission for digital (A/B) encoder signals. TTL inputs for limit and reference point switches. Input for RS-422 signals for index switch.

Interfaces

USB and RS-232 for commanding. I/O lines (analog/digital) for automation. Interface for analog joystick.

Extensive functions, software support

Powerful macro command language. Nonvolatile macro storage, e.g., for stand-alone operation with autostart macro. Data recorder. ID chip detection for fast startup. PID controller, parameter changing during operation. Extensive software support, e.g., for LabVIEW, C, C++, MATLAB, python. PIMikroMove user software.

Scope of delivery incl. 48-V wide-range-input power supply, USB cable, RS-232 cable, network cable for daisy chain and plug adapter for stages with Sub-D 15 connection.

C-663.12	
Function	Mercury Step stepper motor controller
Drive types	2-phase stepper motor
Axes	1
Supported functions	Point-to-point motion. Startup macro. Data recorder for recording operating data such as velocity, position or position error. Internal safety circuitry: Watchdog timer. ID Chip detection (for future use).
Motion and control	
Controller type	PID, parameter changing during operation
Servo cycle time	50 µs
Dynamics profile	Trapezoidal velocity profile
Microstep resolution	1/2048 full step
Encoder input	A/B quadrature, TTL, RS-422; 60 MHz
Limit switches	2 × TTL, programmable
Reference point switches	1 × TTL, programmable
Index switch	1 × RS-422 for index pulse
Stall detection	Automatic motor stop when a programmable position error is exceeded (only in conjunction with sensor)
Electrical properties	
Operating voltage	24 to 48 V DC from external power supply (48 V DC power supply in scope of delivery)
Max. output voltage*	0 V to operating voltage, for direct control of stepper motors
Power consumption, full load	48 W (max.)
Power consumption, no load	3 W
Max. output power (<2 ms)	100 W
Average output power	<48 W
Current limitation per motor phase	2.5 A
Interfaces and operation	
Communication interfaces	USB, RS-232
Motor / sensor connection	HD Sub-D 26 (f)
Controller network	Up to 16 units on a single interface**
I/O lines	4 analog / digital inputs (0 to 5 V /TTL), 4 digital outputs (TTL)
Command set	PI General Command Set (GCS)
User software	PIMikroMove
Application programming interfaces	API for C / C++ / C# / VB.NET / MATLAB / python, drivers for LabVIEW
Manual control	Joystick, Y-cable for 2-D motion, pushbutton box
Miscellaneous	
Operating temperature range	5 to 50 °C (temperature protection switches off at excessively high temperatures)
Mass	0.48 kg
Dimensions	130 mm × 76 mm × 40 mm (incl. mounting rails)

* Depending on the power supply used

** 16 units with USB; 6 units with RS-232

C-863 Mercury Servo Controller

1 Axis, for DC Motors and Brushless DC Motors



- High-speed encoder input to 60 MHz
- Powerful macro programming language, e.g., for stand-alone operation
- Nonvolatile EEPROM for macros and parameters
- Data recorder
- Daisy chain networking
- Connection for joystick

Digital motion controller for DC servo motors

1 axis. Motion control of PI positioning systems with DC motor: Direct motor control; PWM control for fast PI stages with integrated ActiveDrive amplifiers or with brushless motors and integrated block commutation. PID controller. Supports motor brake.

Interfaces and communication

USB and RS-232 interface for commanding. A/B quadrature encoder input. TTL inputs for limit and reference point switches. I/O lines (analog/digital) for automation. Interface for analog joystick. Daisy chain networking for up to 16 axes operated via a common computer interface.

Extensive functions, software support

Powerful macro command language. Nonvolatile macro storage, e.g., for stand-alone operation with autostart macro. Data recorder. PID controller, parameter changing during operation. Extensive software support, e.g., for LabVIEW, C, C++, MATLAB, python. PIMikroMove user software.

C-863.11	
Function	DC motor control, servo control
Axes	1
Supported functions	Point-to-point motion. Startup macro. Data recorder for recording operating data such as motor voltage, velocity, position or position error. Internal safety circuitry: Watchdog timer.
Motion and control	
Controller type	PID controller, parameter changing during operation
Servo cycle time	50 μ s
Profile generator	Trapezoidal velocity profile
Encoder input	A/B quadrature single-ended or differential TTL signal acc. to RS-422; 60 MHz
Stall detection	Automatic motor stop when a programmable position error is exceeded
Limit switches	2 \times TTL (programmable polarity)
Reference point switch	1 \times TTL
Motor brake	1 \times TTL, can be switched by software
Electrical properties	
Max. output voltage*	0 to \pm 15 V for direct control of DC motor
Max. output power	30 W
Current limitation	2 A
Interfaces and operation	
Interface / communication	USB; RS-232, Sub-D 9 (m)
Motor connector	Sub-D 15 (f)
Controller network	Up to 16 units** on a single interface
I/O lines	4 analog / digital inputs, 4 digital outputs (TTL), 5 V TTL
Command set	PI General Command Set (GCS)
User software	PIMikroMove
Software drivers	API for C / C++ / C# / VB.NET / MATLAB / python, drivers for LabVIEW
Manual control	Optional: Pushbutton box, joystick (for 2 axes), Y cable for 2-D motion
Miscellaneous	
Operating voltage	15 to 30 V, in the scope of delivery: external power supply 15 V / 2 A
Max. current consumption	80 mA plus motor current (max. 3 A)
Operating temperature range	5 to 50 $^{\circ}$ C
Mass	0.3 kg
Dimensions	130 mm \times 76 mm \times 40 mm (incl. mounting rails)

* The output voltage depends on the connected power supply.

** 16 units with USB; 6 units with RS-232.

C-884.4DC/C-884.6DC

Motion Controllers for DC motors, 4 or 6 Axes

For Positioners with Closed-Loop DC Motor, USB, RS-232, TCP/IP, SPI, I/O, Joystick



- PID servo control with dynamic parameter switching
- Powerful macro programming language, e.g., for stand-alone operation
- Data recorder
- Integrated interfaces: USB, RS-232, Ethernet, SPI, I/O, joystick
- Trajectory support for 1 or 2-D motion patterns

Digital motion controller for DC servo motors

4 or 6 axes. Dual-core architecture for increased performance and flexibility by separating command processing and position control. Simple adaptation / extension possible for OEM products. Motion control of PI positioning systems with DC motors: Direct motor control, PWM control for PI positioning stages with integrated ActiveDrive amplifiers or integrated block commutation (brushless motors). Supports motor brake.

Motion profiles

Point-to-point, trapezoidal velocity profile. User-definable trajectories (e.g., circles, sine curves) from externally fed points.

Interfaces and communication

Interfaces: TCP/IP, USB and RS-232 for commands. A/B quadrature encoder input. TTL inputs for limit and reference point switches. I/O lines (analog/digital) for automation. USB interface for human interface devices.

Extensive functions, software support

Powerful macro command language. Nonvolatile macro storage, e.g., for stand-alone operation with autostart macro. Data recorder. ID chip detection for fast startup. PID controller, parameter changing during operation. Extensive software support, e.g., for LabVIEW, C, C++, MATLAB, python. PIMikroMove user software.

C-884.4DC / C-884.6DC	
Function	Position control for closed-loop DC motors
Processor	Dual core architecture. Controller on a DSP core, with extendable command interpreter in an ARM core under Linux
Axes	C-884.4DC: 4 / C-884.6DC: 6
Supported functions	Linear vector motion. Point-to-point motion. User-definable trajectories. Startup macro. PI Python. Data recorder for recording operating data such as motor voltage, velocity, position or position error. ID Chip detection.
Motion and control	
Controller type	PID controller, parameter changing during operation
Servo cycle time	100 μ s
Profile generator	Trapezoidal velocity profile
Encoder input	A/B quadrature (TTL differential according to RS-422), 50 MHz; BiSS interface
Stall detection	Automatic motor stop when a programmable position error is exceeded
Limit switches	2 \times TTL per axis (programmable polarity)
Reference point switch	1 \times TTL per axis
Motor brake	1 \times TTL per axis, can be switched per software
Electrical properties	
Max. output voltage*	24 V
Max. output power	240 W
Current limitation	2.5 A per axis
Interfaces and operation	
Communication interfaces	TCP/IP: RJ45/Ethernet; USB: Mini-USB type B; RS-232: Sub-D 9 (m); SPI: DisplayPort
Motor connector	Sub-D 15 (f)
I/O lines	4 analog inputs (-10 to 10 V), 4 digital outputs (5 V TTL) 4 digital outputs (5 V TTL)
Command set	PI General Command Set (GCS)
User software	PIMikroMove
Application programming interfaces	API for C / C++ / C# / VB.NET / MATLAB / python, drivers for LabVIEW
Manual control	USB interface for HID-compliant devices
Miscellaneous	
Operating voltage	External power supply 24 V / 5 A (120 W) included in the scope of delivery
Max. current consumption	C-884.4DC: 11 A / C-884.6DC: 16 A
Current consumption, no load	500 mA
Operating temperature range	5 to 50 $^{\circ}$ C
Mass	C-884.4DC: 1.77 kg / C-884.6DC: 1.97 kg
Dimensions	312 mm \times 153.4 mm \times 59.2 mm (incl. mounting rails)

* The output voltage depends on the connected power supply.

SMC Hydra Motion Controller

For Electromagnetic Motors



- 2-D vector motion with linear interpolation, independent single-axis motions
- Digital inputs and outputs
- Optional: Encoder-based trigger output
- Optional: Position capture input: Position detection in real time via digital input
- Optional: Dynamic position correction

Universal digital motion controller

For DC servo and brushless DC motors (BLDC), linear and torque motors (2 / 3 phases), 2-phase stepper motors. 24 V / 48 VDC output voltage, up to 200 W power per channel.

Maximum output current 10 A per phase (effective). Sine-commutated operation. Automatic detection of the motor phase. PID controller for position and velocity. Servo frequency 4 kHz

Versions

- TT benchtop device with integrated power supply, 2 channels
- CM compact version, 2 channels
- RM 19" rack unit with integrated power supply, 2 channels
- RM 19" rack unit with integrated power supply, 4 channels

Extensive functionality

Extensive software support, e.g., for LabVIEW, dynamic libraries for Windows and Linux

Interfaces

Commanding via TCP/IP, RS-232. RM version only: USB as well. Manual operation with joystick via CAN bus (accessory). Digital inputs and outputs for automation. Opto-decoupled inputs, 4 analog outputs

Default options

- DeltaStar and DeltaStar Eco encoder interface module: Required to control position-controlled drives (rotary or linear encoders). Differential signal transmission for digital (A/B) or analog (sin/cos) encoder signals, inputs for limit switch signals. Please specify when ordering.
Trigger options with DeltaStar: Trigger outputs, position capture input (position detection in real time via digital input)
Trigger options with DeltaStar Eco: Trigger outputs
- Dynamic Position Correction: Position deviations for a selected configuration of linear or rotation stages are determined with a highly accurate measuring system and saved in a table of corrections in the controller. Correction is also dynamic. Single-axis mapping, only available as factory default in conjunction with a PI positioning system. Please specify when ordering.

SMC Hydra	
Function	Motion controller for electromagnetic motors Hydra TT (benchtop device) Hydra CM (compact device) Hydra RM (19" rack unit)
Motor channels	Hydra TT: 2 Hydra CM: 2 Hydra RM: 2 / 4
Sensor channels	Hydra TT: 2 Hydra CM: 2 Hydra RM: 2 / 4
Motion and Control	
Servo characteristics	PID controller, also adaptive for position and velocity as well as velocity and acceleration feed-forward, parameter change on-the-fly
Servo frequency	4 kHz
Profile generator	Trapezoidal velocity profile, setting of maximum velocity and acceleration 2D vector control with linear interpolation
Encoder input	Analog signals (sin/cos) max. 150 kHz (line count) Digital signals (A/B differential via RS-422) max. 4 MHz (line count) Positioning range: $\pm 4.3 \cdot 10^2$ mm / deg
Stall detection	Position error, peak current, I ^t limit
Microsteps per full step	3000
Limit switches	2 per channel, 5 to 24 V (programmable polarity) N/O contact / N/C contact; NPN / PNP
Reference point switch	Index signal of the encoder
Motor brake	1x per channel, TTL, configurable via software
Electrical properties	
Maximum output voltage	24 V / 48 V
Maximum output power per channel	200 W
Maximum output current per channel	10 A _{rms}
Interfaces and operation	
Interface for communication	TCP/IP 10/100 Mbit, RS-232: Sub-D 9-pin (m), 9.6 to 115.2 kBaud Hydra RM: USB as well
Motor connection per channel	Sub-D 15-pin (f)
Sensor connection per channel	Sub-D 15-pin (f)
I/O ports	6 inputs, opto decoupled, 5 – 24 V (2 each reserved per channel for limit switch) Input for motor switch-off on all axes, opto decoupled Open drain output (100 mA) 2 TTL outputs 4 analog outputs, 10-bit resolution, 0 to 3.3 V (not for Hydra TT) With DeltaStar interface as default option: Fast trigger output, max. 400 kHz, equidistant or from freely definable table (max. 3000 axis positions) Position capture input, max. 4 kHz (>3,000,000 axis positions) With the default DeltaStar Eco interface option: Trigger output, 2 kHz, equidistant, jitter 10-30 μ s
Command set	Venus-3 ASCII interpreter Dynamic library for PI General Command Set (GCS)
User software	Venus-3 demo program LabVIEW (source code & executable) Terminal program (Venus-3 DLL) PIMikroMove via dynamic libraries for Windows
Software drivers	LabVIEW drivers, dynamic libraries for Windows and Linux (GCS) GCS2 DLL 32/64-bit Venus3 DLL 32/64-bit / .net wrapper DLL incl. example source code
Supported functions	Linear vector motion, independent point-to-point motions, automatic detection of the motor phase
Manual operation	Joystick via CAN bus (accessory)
Ó	Switch-off via external switch, motor driver overload protection, motor overheat protection (I2t), system overcurrent protection

SMC Hydra

Miscellaneous	
Operating voltage	Hydra TT: 90 - 260 V, integrated wide-range-input power supply Hydra CM: 24 V / 48 V, external power supply (not in scope of delivery) Hydra RM: 90 - 260 V, integrated wide-range-input power supply
Max. power consumption	Hydra TT: 300 W Hydra CM: 120 W Hydra RM: 1000 W
Max. current consumption	11 A
Operating temperature range	10 to 40 °C
Weight	Hydra TT: 2.65 kg Hydra CM: 0.45 kg Hydra RM: 6 kg
Dimensions	Hydra TT: 225 mm x 515 mm x 56 mm Hydra CM: 76 mm x 156 mm x 56 mm Hydra RM: 84 HP, 2 RU, depth 310 mm

Engineering Design Expertise and Customization

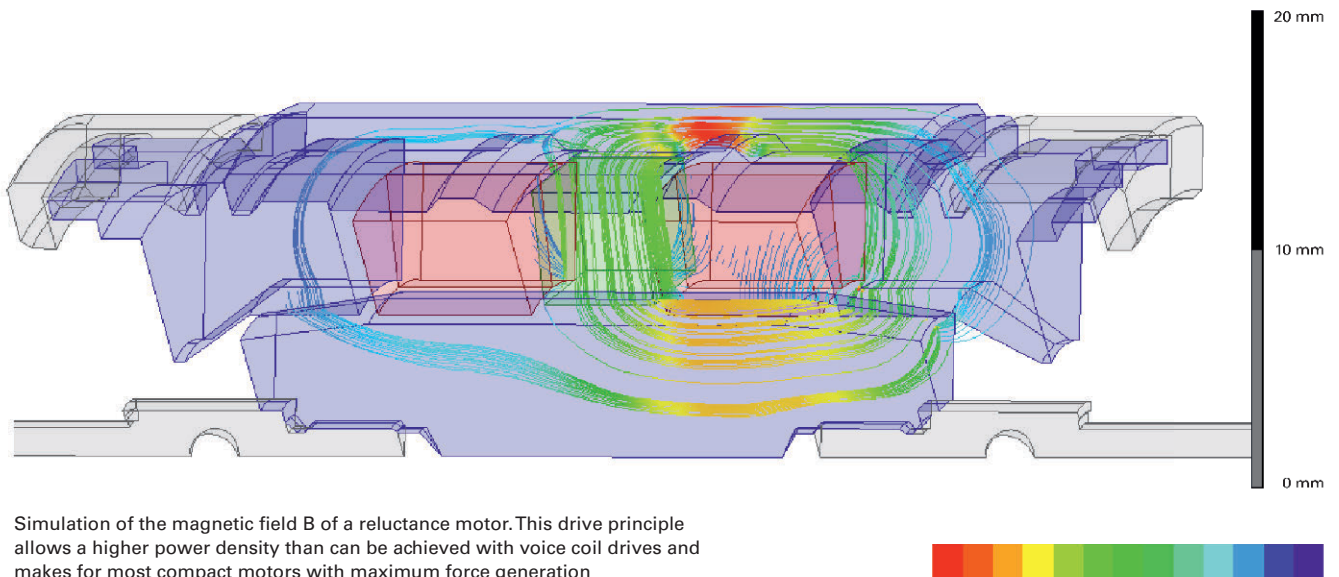

Unique Technological Breadth

The technological diversity of the PI Group is unrivalled all over the world. PI develops, manufactures, and qualifies all its core technologies itself. PI is therefore not dependent on components available on the market. That puts PI in a position to offer its customers the most advanced products for motion and positioning tasks – without technological restriction.

Customized Solutions

With this background, PI develops positioning solutions with innovative drive technologies for high-tech applications worldwide. PI covers the whole motion range from finger-tip sized nanopositioners to large-scale stages with long travel ranges, through their plethora of different drive and guiding systems.

Core Technologies

- In-house manufacturing of piezo components and piezo actuators
- Magnetic direct drives: Linear motors and voice coil
- Air bearings, magnetic, and flexure guides
- Comprehensive range of piezo motor technologies
- Nanometrology sensors
- Parallel-kinematic systems for positioning in six axes (hexapods)
- Motion control technology
- Software

Global Service and After-Sales



On-site training is key to optimize and maximize the potential of new PI systems

Start-Up, User Training and Life Long Support

PI is dedicated to supporting its customers right from the initial consultation through to when a customer has purchased a PI system. Beyond that, PI's services division is committed to ensuring that every aspect of owning a PI system is catered for.

Global Coverage

Supported by four Global Service Hubs in Asia, China, Europe and USA, with field product specialists working from these hubs, PI is able to support all technologies and customer applications via this global services team.

PI's Standard On-Site Services

- Setup and Commissioning – On-site support to un-box, set-up and commission the PI system.
- Training Program – User training on software and programming, through to optimization of system performance.
- Maintenance Systems Health Check – Preventative maintenance to prolong the life of the motion device
- Support – Ongoing remote and on-site support to maximize system uptime and provide maintenance for the whole life of any system

Contracted Services

Customers subscribing to Contractual Support Services will receive commitment from PI to achieving agreed Service Levels. These include responding to the customer's first contact and providing remote technical support, through to response times for a PI expert to be on site, either to repair or replace a defective unit.

Extended Warranty

Most customer applications require PI's systems to be operational beyond the standard warranty period. Extending the warranty for additional year(s), is simply extending the customers peace of mind and PI's commitment that the product will not fail due to poor workmanship or faulty materials. Should a customer's system then fail due to these conditions, PI will cover the costs to repair or replace it.



PI HQ, Karlsruhe, Germany

Headquarters

GERMANY

**Physik Instrumente (PI)
GmbH & Co. KG**
Auf der Roemerstrasse 1
76228 Karlsruhe
Phone +49 721 4846-0
Fax +49 721 4846-1019
info@pi.ws
www.pi.ws

PI miCos GmbH
Freiburger Strasse 30
79427 Eschbach
Phone +49 7634 5057-0
Fax +49 7634 5057-99
info@pimicos.com
www.pi.ws

PI Ceramic GmbH
Lindenstrasse
07589 Lederhose
Phone +49 36604 882-0
Fax +49 36604 882-4109
info@piceramic.com
www.piceramic.com



© Physik Instrumente (PI) GmbH & Co. KG

All contents, including texts, graphics, data etc., as well as their layout, are subject to copyright and other protective laws. Any copying, modification or redistribution in whole or in parts is subject to a written permission of PI.

Although the information in this document has been compiled with the greatest care, errors cannot be ruled out completely. Therefore, we cannot guarantee for the information being complete, correct and up to date. Illustrations may differ from the original and are not binding. PI reserves the right to supplement or change the information provided without prior notice.

Subsidiaries

USA (East) & CANADA

PI (Physik Instrumente) L.P.
Auburn, MA 01501
www.pi-usa.us

USA (San Francisco Bay Area)

PI (Physik Instrumente) L.P.
Sausalito, CA 94965
www.pi-usa.us

ITALY

Physik Instrumente (PI) S. r. l.
Bresso
www.pionline.it

FRANCE

PI France SAS
Aix-en-Provence
www.pi.ws

JAPAN

PI Japan Co., Ltd.
Tokyo
www.pi-japan.jp

CHINA

**Physik Instrumente
(PI Shanghai) Co., Ltd.**
Shanghai
www.pi-china.cn

SOUTHEAST ASIA

**PI (Physik Instrumente)
Singapore LLP**
Singapore
www.pi-singapore.sg
For ID / MY / PH / SG / TH / VNM

KOREA

PI Korea Ltd.
Seoul
www.pikorea.co.kr

USA (West) & MEXICO

PI (Physik Instrumente) L.P.
Irvine, CA 92620
www.pi-usa.us

UK & IRELAND

PI (Physik Instrumente) Ltd.
Cranfield, Bedford
www.physikinstrumente.co.uk

NETHERLANDS

PI Benelux B.V.
Sint-Oedenrode
www.pi.ws/benelux

SPAIN

Micos Iberia S.L.
Vilanova i la Geltrú
www.pimicos.es

PI Japan Co., Ltd.
Osaka
www.pi-japan.jp

**Physik Instrumente
(PI Shanghai) Co., Ltd.**
Beijing
www.pi-china.cn

TAIWAN

**Physik Instrumente (PI)
Taiwan Ltd.**
Taipei
www.pi-taiwan.com.tw