

Compact High-Precision Direct Drive Linear Stage

Ideal for Scanning, Measuring, Imaging, Alignment

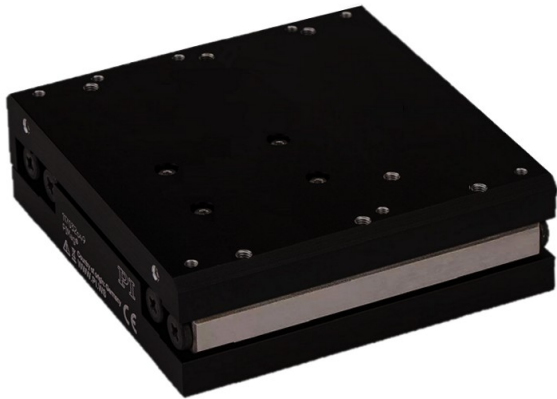

V-141

- Very compact footprint
- Direct drive motor for efficient, dynamic performance
- Crossed-roller bearings for true straightness and flatness
- Direct-measuring incremental Encoder for the best accuracy and repeatability

[Preliminary Datasheet](#)

Product overview

V-141 direct-drive linear stages are designed for accuracy, precision, long life, ease of use, and can be mounted in any orientation. A version with integrated counterbalance and brake is available for vertical operation.

Even though compact, V-141 linear stages offer superior travel accuracy, flatness, and performance compared to bigger stages. With a powerful, non-cogging, direct drive motor, the V-141 linear stage family performs well in production environments. The ultra-precision cross roller bearings are intended to be low maintenance for the life of the stage.

The V-141 is designed for XY and XYZ mounting. The Z version comes with a brake and a pneumatic counterbalance.

Three phase motors for higher dynamics and friction-free, maintenance-free operation

The three-phase linear motors driving the V-141 stage family transfer their force directly and friction-free to the motion platform. This eliminates backlash and play that can result from mechanical components like gears and screws in the drivetrain. Ideal for high-velocity, high-acceleration applications, these motors feature a maintenance-free, frictionless design, ensuring longevity in demanding 24/7 operations. The controller's current limit settings allow easy motor disablement, preventing damage to the stage or the application.

Crossed roller bearings improve load capacity, accuracy and lifetime

Crossed roller bearings offer a superior level of smoothness, straightness, and flatness, close to air bearing performance. By replacing the point contact of ball bearings with a line contact, rollers become considerably stiffer, requiring less preload. This reduction in friction enables smoother running and higher accuracy. Crossed roller bearings can also support more direct loads and moment loads. The anti-creep mechanism prevents roller drift, enhancing reliability. Cleanroom grease is applied for low-maintenance operation.

Incremental encoder

V-141 stages are equipped with linear encoders that measure position with utmost accuracy directly at the motion platform, enhancing linearity and ensuring immunity to mechanical play and elastic deformation of indirect measuring methods. A home signal is built in to initiate the stage.

Choosing the right precision linear stage and motion controller

Selecting the right linear stage is pivotal for optimal performance in high-precision motion applications, such as semiconductor inspection and photonics alignment. Factors such as resolution, guiding accuracy, and repeatability must be carefully considered. These linear stages offer excellent geometric accuracy (flatness, straightness, pitch, and yaw) along with 100 nanometers bi-directional repeatability in a very compact package. With high dynamic properties, including 0.5 g acceleration and 500 mm/sec velocity, these compact motorized stages are ideal for 24/7 automation of highly accurate positioning tasks required for micro-assembly, alignment or mass production of precision devices.

Partnered with PI's A-8xx series motion controllers, these stages achieve unparalleled motion performance. PI's EtherCAT®-based controllers offer remarkable flexibility, facilitating the seamless integration of third-party equipment compatible with EtherCAT®. Advanced algorithms in the A-8xx series motion controllers, such as PILOT allow for higher dynamics with reduced motor currents, virtually increasing the motor's force constant. Choose the compact V-141 for precision, reliability, and efficiency in your motion applications.

Accessories and options

- Brake and counterbalance for vertical use
- Single or multi-axis, ACS motion controllers and servo drives, integrated or distributed
- Cables compatible with the A-8xx series, ACS-powered controllers.
- Multi-axis assemblies
- Granite support base

Application fields

Sample inspection. Precision micro-assembly. Research. Biotechnology. Semiconductor test and inspection. Metrology. General Automation. Device assembly. Laser Micro-processing. Pick and place. Alignment.

Specifications

Motion	V-141.025x1	V-141.050x1	Unit	Tolerance
Active axes	X - axis			
Travel range	25	50	mm	max
Pitch ⁽¹⁾	50	60	μrad	max.
Yaw ⁽¹⁾	50	50	μrad	max.
Straightness ⁽¹⁾	1.0	1.0	μm	max.
Flatness ⁽¹⁾	1.0	1.0	μm	max.
Bidirectional repeatability	± 0.1	± 0.1	μm	max.
Positioning accuracy, calibrated ⁽²⁾	± 0.5	± 0.5	μm	max.

Mechanical	V-141.025x1	V-141.050x1	Unit	Tolerance
Bearing	Ultra-precision, cross-roller bearing			
Motion platform	80 x 80	110 x 80	mm	
Stage Height	25		mm	
Load capacity, ⁽³⁾	50		N	max.
Moving mass, unloaded	0.24	0.33	kg	typ.
Overall mass	0.75	1.0	kg	typ.
Materials	Aluminum			

Drive properties	V-141.025x1	V-141.050x1	Unit	Tolerance
Drive type				
Intermediate circuit voltage	48	48	V DC	max.
Peak force	17	17	N	max.
Nominal force	6	6	N	max.
Force constant, RMS	11.7	11.7	N/Arms	typ.
Peak Current	1.5	1.5	A	max.
Nominal Current, RMS	0.5	0.5	A	max.
Resistance, phase-phase	25	25	Ω	±10%
Inductance, phase-phase	8.8	8.8	mH	±10%
Back EMF, phase-phase	12	12	V/m/s	±10%
# of Pole Pairs				
Magnet Pitch NN	NA	NA	mm	typ.
Linear Velocity ⁽³⁾	500	500	mm/s	max.
Acceleration ⁽³⁾	5	5	m/s ²	max.

NOTES

⁽¹⁾ Dependent on the quality of the mounting surface, the payload, orientation, and external forces that act on the stage. Please contact PI for application-specific parameters. The specified values are static (no rotary motion during measuring) and without load.

⁽²⁾ The specified values are based on error compensation enabled by the PI controller. The positioner must be ordered with a controller from PI to reach these values. Accuracy values assume short-term duration and do not consider the long-term effects of thermal drift on the stage.

⁽³⁾ Can be limited by imbalance of the payload or the controller and the drive.

Measurement Sensor	V-141.xxxA1
Integrated sensor	Incremental encoder
Sensor signal type	Sin/cos, 1 V peak-peak
Sensor resolution	100nm
Reference point switch	1 at middle of travel, 1 V peak-peak

Miscellaneous	V-141.xxxx1
Motor/Encoder Connector	DB15 (male)
Operating Temp Range	5 to 50 °C
Recommended Controller	A-81x Series
	A-82x Series
Recommended Cables	A-85x Series

Drawings / Images

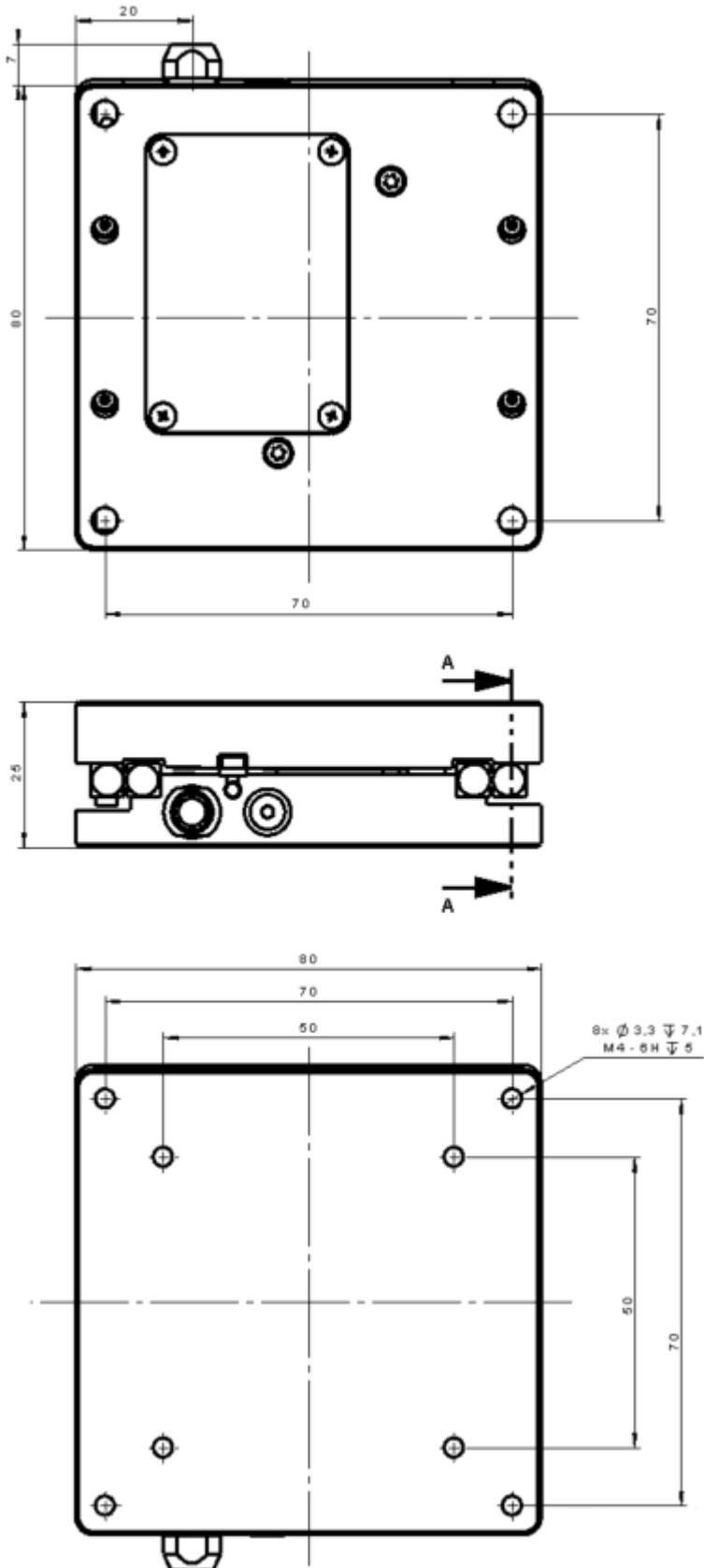

V-141.025A1, dimensions in mm

Ordering Information

V-141.025A1

PI linear stage, 25mm travel, cross roller bearing, 80mm wide motion platform, incremental sin/cos 1Vpp encoder, brushless 3-phase direct-drive motor

V-141.050A1

PI linear stage, 50mm travel, cross roller bearing, 80mm wide motion platform, incremental sin/cos 1Vpp encoder, brushless 3-phase direct-drive motor

V-141.025A1BZ

PI linear stage, 25mm travel, cross roller bearing, 80mm wide motion platform, incremental sin/cos 1Vpp encoder, brushless 3-phase direct-drive motor, counterbalance and brake

V-141.050A1BZ

PI linear stage, 50mm travel, cross roller bearing, 80mm wide motion platform, incremental sin/cos 1Vpp encoder, brushless 3-phase direct-drive motor, counterbalance and brake