

Methods to Improve Piezo Dynamics: Preshaping / DDL / APC

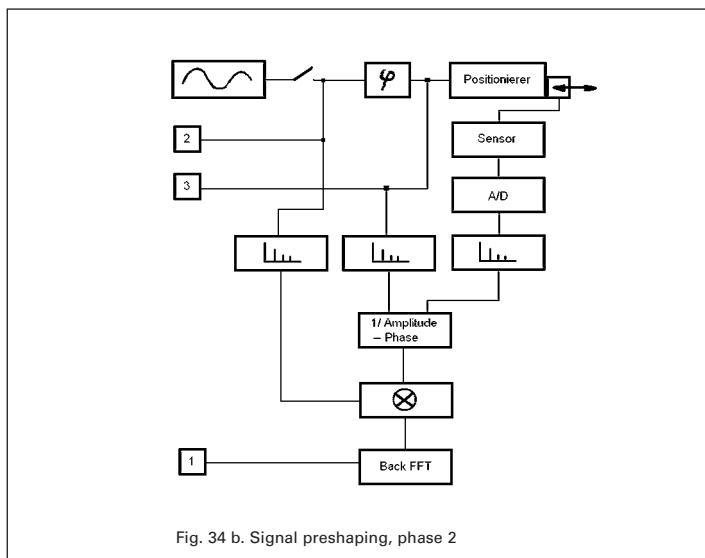
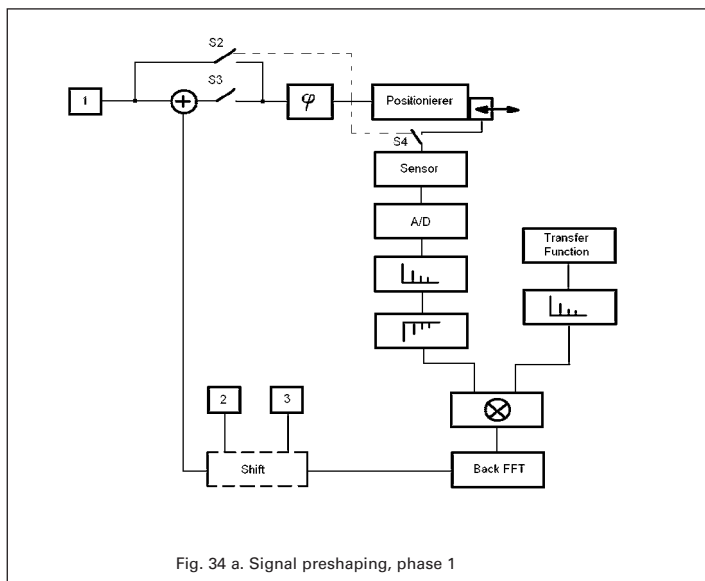

Signal Preshaping / Dynamic Digital Linearization (DDL)

Signal Preshaping, a patented technique, can reduce rolloff, phase error and hysteresis in applications with repetitive (periodic) inputs. The result is to improve the effective bandwidth, especially for tracking applications such as out-of-round turning of precision mechanical or optical parts. Signal Preshaping is implemented in object code, based on an analytical approach in which the complex transfer function of the system is calculated, then mathematically transformed and applied in a feedforward manner to reduce the tracking error.

Signal Preshaping is more effective than simple phase-shifting approaches and can improve the effective bandwidth by a factor of 10 and in multi-frequency applications.

Frequency response and harmonics (caused by nonlinearity of the piezo-effect) are determined in two steps using Fast Fourier Transformation (FFT), and the results are used to calculate the new control profile for the trajectory. The new control signal compensates for the system non-linearities.

For example, it is possible to increase the command rate from 20 Hz to 200 Hz for a piezo system with a resonant frequency of 400 Hz without compromising stability. At the same time, the tracking error is reduced by a factor of about 50.

Dynamic Digital Linearization (DDL)

DDL is similar in performance to Input Preshaping, but is simpler to use. In addition, it can optimize multi-axis motion such as a raster scan or tracing an ellipse. This method requires no external metrology or signal processing.

DDL uses the position information from capacitive sensors integrated in the piezo mechanics (requires direct metrology) to calculate the optimum control signal. As with preshaping, the result is an improvement in linearity and tracking accuracy of up to 3 orders of magnitude.

APC: Advanced Piezo Control Faster and More Stable

An alternative control concept is available for the modular E-712 controller for nanopositioning systems: Advanced Piezo Control. It is based on a state controller which, in turn, is based on a model of the positioning system.

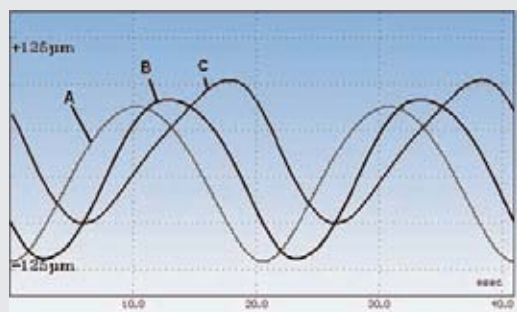

Fig. 35. No preshaping
A: Control input signal (expected motion)
B: Actual motion of system
C: Tracking error

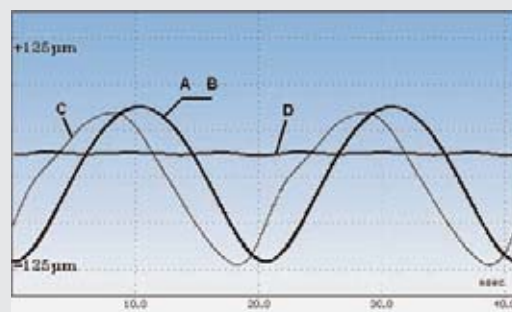

Fig. 36. Signal after preshaping phase 2
A: Expected Motion (old control signal)
B: Actual motion of system
C: New control input (produced by preshaping)
D: Tracking error

DDL: Dynamic Digital Linearization

Nanometer Trajectory during Dynamic Scans

Improved Piezo Control: Dynamic Digital Linearization (DDL)

Conventional piezo controllers cannot completely avoid phase-shift and tracking errors in applications with rapid, periodic motion. This is due in part to the non-linear nature of the piezoelectric material, the finite control bandwidth and the inherent limitations of P-I (proportional-integral) servo-control, which only reacts when a position error is detected. The DDL option (ordering number E-710.SCN), available with

recent digital piezo controllers such as E-753 (single-channel, see p. 2-108) or E-712 (multi-channel, see p. 2-140), solves this problem. This technology, developed by PI, reduces the error between the current and desired position to imperceptible values. The dynamic linearity and effectively usable bandwidth are thus improved by up to three orders of magnitude. DDL is of benefit to single- and multi-axis applications where motion follows a given trajectory repeatedly (see measurement curves).

Ordering Information

E-710.SCN
Firmware Upgrade DDL
(Dynamic Digital Linearization)

Available for controllers:
E-712, E-725 and E-753.

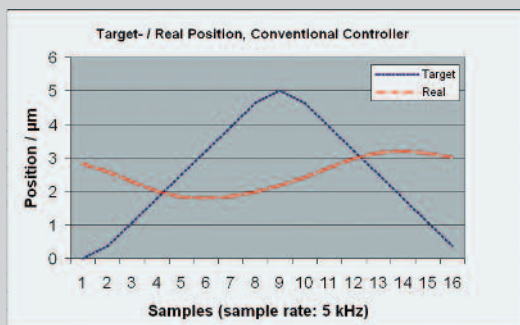

Nanopositioning systems with conventional PID controller: Single axis movement with a 312 Hz triangular signal. The difference between target and actual position can be up to 2.6 μm .

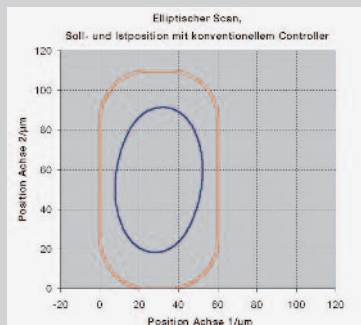

Elliptical scan with a XY piezo scanner and conventional P-I-servo controller. The outer curve shows the desired position, the inner curve shows the actual motion.

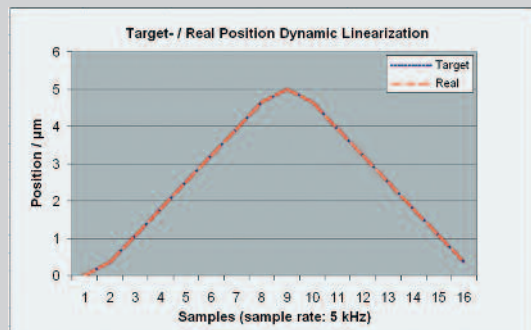

Nanopositioning system with DDL option: The same single axis movement as above, with 312 Hz triangular signal. The difference between target and actual position is practically unobservable and is about 7 nanometers.

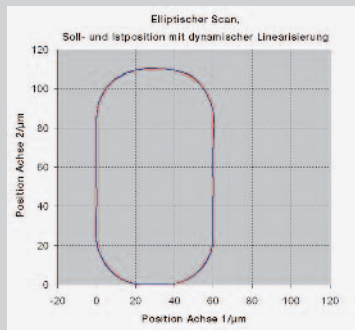

The same scan as before but with a DDL controller. The tracking error is reduced to a few nanometers, desired and actual position cannot be distinguished in the graph.

APC: Advanced Piezo Control Alternative Control Concept for Faster Settling

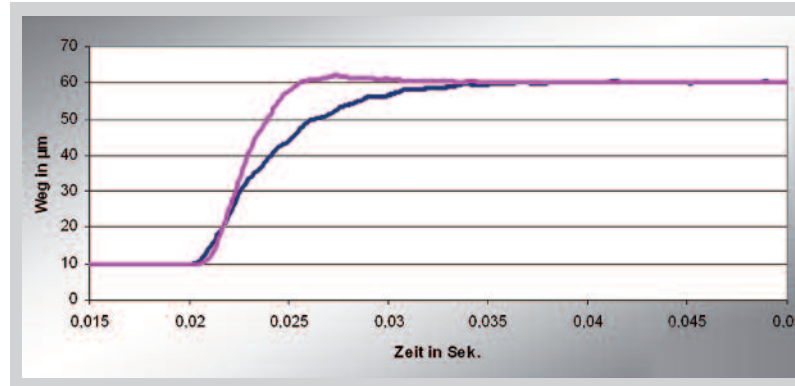

Transient response of an system with optimized PID parameters (blue) and Advanced Piezo Control (pink).

An alternative control concept is available for the modular E-712 controller for nanopositioning systems: Advanced Piezo Control. It is based on a state controller which, in turn, is based on a model of the positioning system.

Advanced Piezo Control actively damps the resonance frequency, in contrast to conventional PID controllers with notch filter where the mechanical resonance is cut out of the excitation spectrum.

APC: Advanced Piezo Control Faster and More Stable

The consequences are faster settling times and lower sensitivity with respect to interferences from the outside.

The phase trueness is significantly improved compared to the damping with one or even two notch filters. This has immediate effects on the trajectory trueness and the settling response.

Limitations of the Advanced Piezo Control

If the mechanical system has too many resonances close together, or if the resonance frequency to be damped is about 1 kHz or more, the state controller in this form no longer has any advantage over conventional PID controllers. Please discuss your application with us.

Ordering Information

E-712.U1
Firmware Upgrade Advanced Piezo Control

Advanced Piezo Control is also available for the E-753 (1 Channel) and for the E-725 (3 Channels). Ask your PI Sales Department.

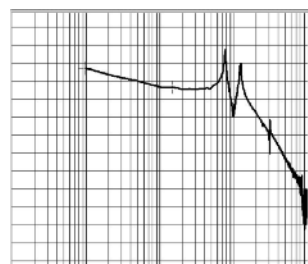

Bode plot of an unloaded, open loop system with two resonance frequencies.

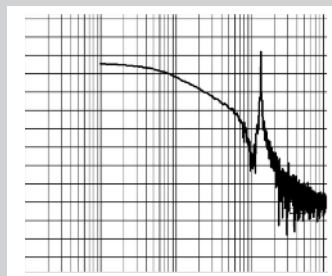

Bode plot of a closed loop system with one notch filter at the first resonance.

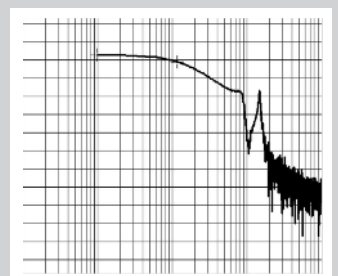

Bode plot of an system controlled with Advanced Piezo Control. The resonances are better suppressed, the phase deviation is lower compared to the suppression with a notch filter.