



Products 2017

AT A GLANCE

Contents

Linear Motor Stages 04



V-731 High-Precision XY Stage	04
V-522, V-524, V-528 High-Dynamics PIMag® Linear Stage	06
V-551 PIMag® Precision Linear Stage	07
V-508 PIMag® Precision Linear Stage	08
V-408 PIMag® Linear Stage	09
V-412, V-418, V-423 High-Load Linear Stage	10

Stages with Stepper, DC and Brushless DC (BLDC) Motors 11

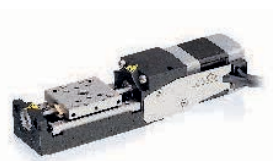

L-505 Compact Linear Stage	11
L-402 Miniature Linear Stage	12
L-220 High-Resolution Linear Actuator	14
L-239 High-Load Linear Actuator	15
L-310 Precision Z Stage	16
L-611 Precision Rotation Stage	17
L-731 Precision XY Stage	18

Air Bearing Stages 20



A-110 PIGlide LC Linear Stage with Air Bearings	20
A-141 PIGlide MB Miniature Linear Air Bearing Stage	22
A-62x PIGlide RM Rotation Stage with Air Bearing	24

Motion Control for DC, Stepper and Linear Motors 26



Solutions for Motion Centric Industrial Automation Motion Control	26
Overview of Available Modules from ACS	28
C-885 PIMotionMaster	30
C-884.4DC / C-884.6DC Motion Controllers for DC Motors	32
C-663.12 Mercury Step Stepper Motor Controller	34
C-891 PIMag® Motion Controller	36

Hexapods: 6-Axis Parallel-Kinematic Robots 38



H-855 Modular 6-Axis Hexapod	38
H-825 6-Axis Hexapod	40
H-840 6-Axis Hexapod	40
H-850 6-Axis Hexapod	41
H-811.I2 6-Axis Miniature Hexapod	41
H-860 High Dynamics Motion Hexapod	42
C-887.52x Hexapod Motion Controller	44

Piezomotor Stages, Hexapods and Motion Controllers 46



Q-821 Q-Motion® Miniature SpaceFAB Robot	46
Q-845 Q-Motion® SpaceFAB	48
N-865 NEXACT® SpaceFAB	50
E-873.3QTU Q-Motion® Servo Controller	52
E-872.401 Q-Motion® Piezomotor / PiezoMike Drive Electronics	53
U-780 PILine® XY Stage System with Controller and Joystick	54
N-331 PICMAWalk Walking Drive and	
E-712.1AN, E-712.2AN, E-712.3AN Digital Controller	56

Nanopositioning with Piezo Stages, Piezo Controllers 58



P-616 NanoCube® Nanopositioner	58
S-335 Fast Tip / Tilt Platform	60
P-545.xC8S PInano® Cap XY(Z) Piezo System	62
E-727 Digital Multi-Channel Piezo Controller	64

Engineered System Capabilities 66

Fast Multi-Channel Photonics Alignment Systems 68

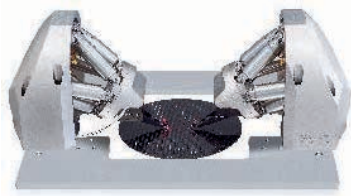

F-712.HA1 / F-712.HA2 High-Precision Fiber Alignment System	68
F-712.MA1 / F-712.MA2 High-Precision Fiber Alignment System	70
F-712.HU1 Fast Multi-Channel Photonics Alignment System	72

Options and Capabilities for Piezo Electrics, PI Ceramic News 74

Technology Glossary 76

The PI Group Milestones 78

V-731 High-Precision XY Stage

High Travel Accuracy and Stability, Magnetic Direct Drive



- >> Direct Metrology
- >> PIMag® Magnetic Linear Motors

Technology Glossary page 76

- Travel range 205 mm × 205 mm (8")
- Unidirectional repeatability to 0.05 μm
- Velocity to 200 mm/s
- Incremental encoder with 10 nm resolution
- Option with stepper motor: L-731

V-731, dimensions in mm

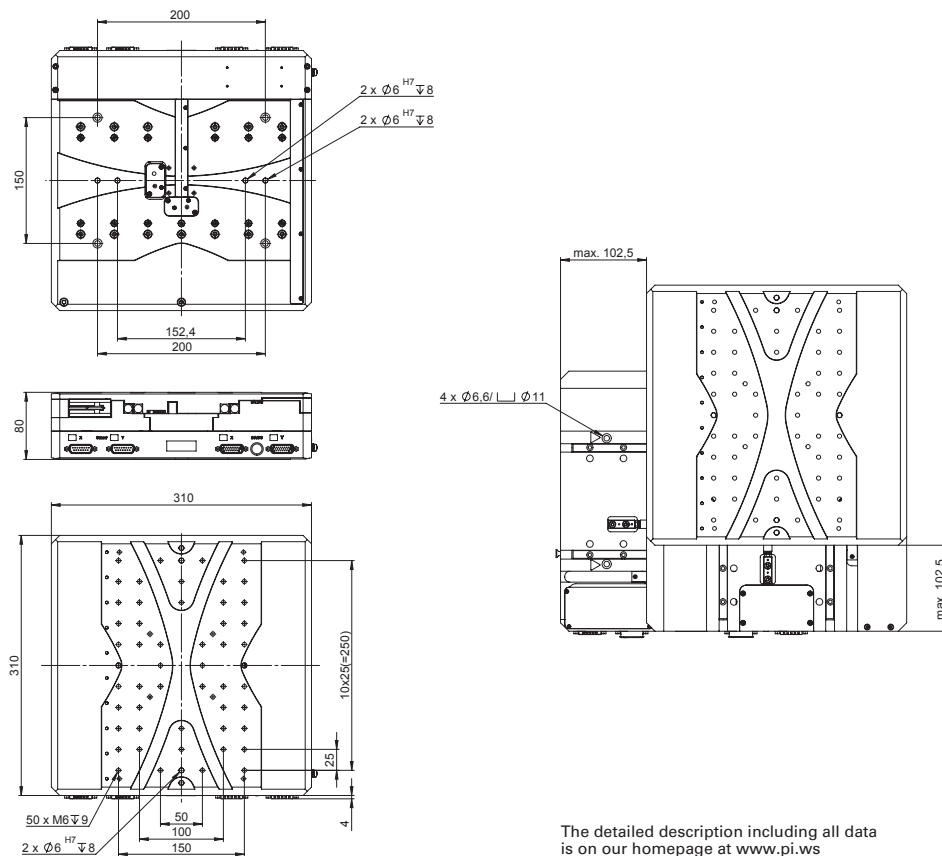

The detailed description including all data is on our homepage at www.pi.ws

	V-731.096111	Unit	Tolerance
Motion and positioning			
Active axes	X,Y		
Travel range	205 × 205	mm	
Integrated sensor	Incremental linear encoder		
Sensor resolution*	10	nm	
Sensor signal period	20	µm	
Minimum incremental motion	0.02	µm	typ.
Unidirectional repeatability	0.1	µm	typ.
Bidirectional repeatability	±0.5	µm	typ.
Pitch	±75	µrad	typ.
Yaw	±75	µrad	typ.
Straightness / flatness	±3	µm	typ.
Velocity	200	mm/s	max.
Reference and limit switches	optical		
Mechanical properties			
Load capacity	50	N	
Permissible torque in θ_x, θ_y	125	N·m	
Permissible torque in θ_z	125	N·m	
Moved mass in X	9.84	kg	
Moved mass in Y	5.6	kg	
Overall mass	19.4	kg	
Guiding	Crossed roller guide with anti-creep system		
Drive properties			
Motor type	Linear motor, ironless		
Intermediate circuit voltage	24	V	DC, max.
Peak force	100	N	typ.
Nominal force	21	N	typ.
Peak current, effective	5	A	typ.
Nominal current, effective	1.1	A	typ.
Force constant, effective	19.9	N/A	typ.
Resistance phase-phase	5.5	Ω	typ.
Inductivity phase-phase	1.8	mH	typ.
Back EMF phase-phase	16	V·s/m	max.
Magnetic periods	30	mm	
Miscellaneous			
Operating temperature range	10 to 50	°C	
Humidity	20 – 90 % rel., not condensing		
Material	Aluminum, black anodized		
Motor connection	2 × HD Sub-D 26 (m)		
Sensor connection	2 × Sub-D 15 (f)		
Recommended controller	SMC Hydra ACS SPii+EC C-891		

* with SMC Hydra. Other interpolation factors are available as an option.
All cables required for operation with the recommended controller are included in the scope of delivery.
Cable for connecting to other controllers can be ordered as accessory.

V-522, V-524, V-528 High-Dynamics PIMag® Linear Stage

Voice Coil-Direct Drive with Direct Position Measurement



- Fast scanning and positioning
- Travel ranges 5 mm, 10 mm, 20 mm
- Scanning frequencies of more than 10 Hz
- Max. velocity 250 mm/s
- Crossed roller bearings for the highest precision

>> Direct Metrology
>> PIMag® Magnetic Linear Motors

Technology Glossary page 76

	V-522.1AA V-522.1AB	V-524.1AA V-524.1AB	V-528.1AA V-528.1AB	Unit	Tolerance
Min. incremental motion	20	20	20	nm	typ.
Bidirectional repeatability	±120	±120	±120	nm	max.
Straightness / Flatness	0.5	0.5	0.5	µm	max.
Velocity	250	250	250	mm/s	max.
Load capacity in Z	100	100	100	N	max.
Nominal force	4	3.8	2.9	N	nominal

V-52x, dimensions in mm

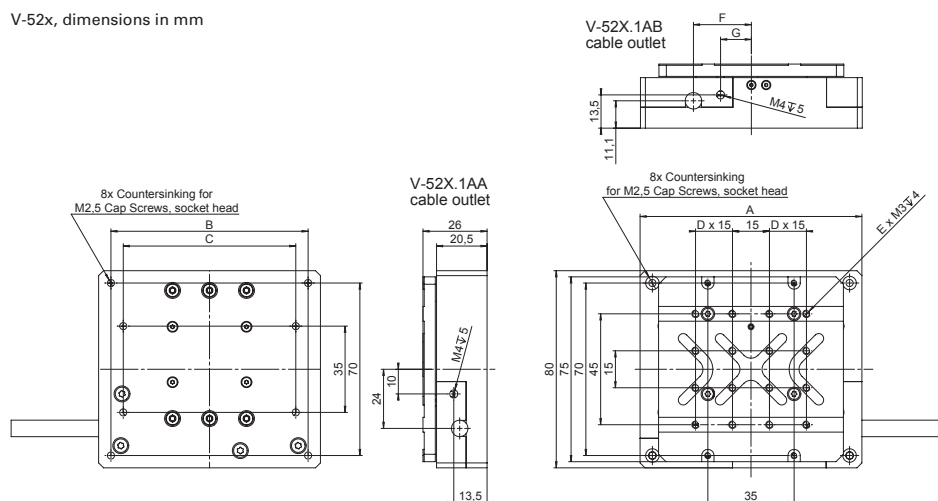

	V-522.1AA	V-522.1AB	V-524.1AA	V-524.1AB	V-528.1AA	V-528.1AB
A	80	80	90	90	120	120
B	70	70	80	80	110	110
C	70	70	70	70	80	80
D	1	1	1	1	2	2
E	16	16	16	16	24	24
F	-	21	-	23,5	-	28,5
G	-	10	-	12,5	-	17,5

The detailed description including all data is on our homepage at www.pi.ws

V-551 PIMag® Precision Linear Stage

High Velocity and Precision due to Magnetic Direct Drive



- >> Direct Metrology
- >> PIMag® Magnetic Linear Motors

Technology Glossary page 76

- Travel ranges to 230 mm
- Velocity up to 0.5 m/s
- Absolute encoder with 1 nm resolution
- Highest precision with PIONe linear encoder: Minimum incremental motion 0.5 nm
- Excellent guiding accuracy to $\pm 1 \mu\text{m}$ straightness / $\pm 2 \mu\text{m}$ flatness
- Compact design with 160 mm width

	V-551.2x	V-551.4x	V-551.7x	Unit	Tolerance
Travel range	60	130	230	mm	
Velocity	0.5	0.5	0.5	m/s	max.
Load capacity in Z	150	150	150	N	max.

	V-551.xB	V-551.xD
Encoder options		
Integrated Sensor	Absolute encoder	PIONe incremental linear encoder
Min. incremental motion	2 nm	0.5 nm
Bidirectional repeatability	$\pm 0.05 \mu\text{m}$	$\pm 0.05 \mu\text{m}$

V-551, dimensions in mm

	V-551.2x	V-551.4x	V-551.7x
Stroke	60	130	230
A	220	290	450
B	210	280	440
C	60	120	120
D	1	1	3
E	-	40	40
F	1	1	3

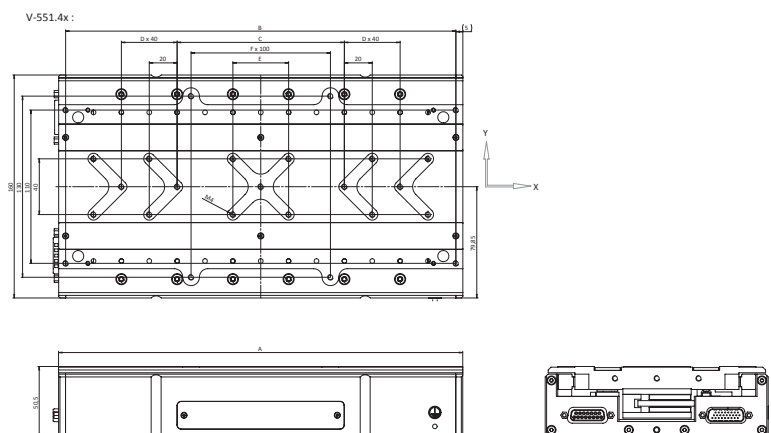

The detailed description including all data is on our homepage at www.pi.ws

V-508 PIMag® Precision Linear Stage

Versatile Options for Adapting to Requirements

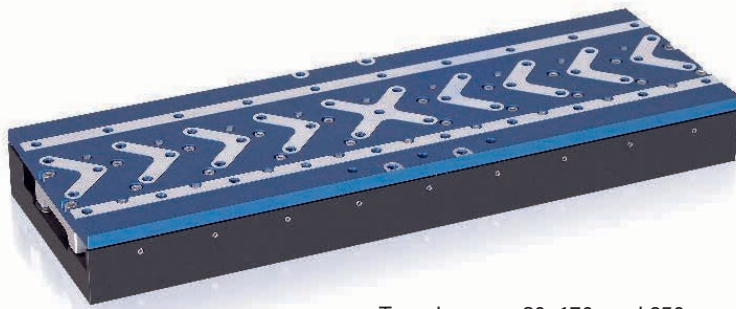

- Travel ranges 80, 170, and 250 mm
- Ironless or iron core linear motor

- >> Direct Metrology
- >> PIMag® Magnetic Linear Motors

Technology Glossary page 76

- Incremental or absolute linear encoder, various resolutions
- Compact cross section: 80 × 25 mm
- Crossed roller bearings for high load capacity

Preliminary data	V-508.3	V-508.6	V-508.9	Unit	Tolerance
Travel range	80	170	250	mm	
Pitch / yaw	±50	±100	±150	μrad	max.
Straightness / Flatness	±2	±5	±10	μm	max.
Velocity, unloaded	1	1	1	m/s	max.
Load capacity in Z	100	100	100	N	max.

Drive properties	V-508.xx1	V-508.xx2		
Drive type	Linear motor, ironless, 3-phase	Linear motor, iron core, 3-phase		
Peak force	12	14	N	typ.

Encoder options	V-508.x3	V-508.x5	V-508.xB
Integrated sensor	Incremental linear encoder	PIOne incremental linear encoder	Absolute encoder
Minimum incremental motion	20 nm	0.5 nm	3 nm
Bidirectional repeatability	±0.05 μm	±0.05 μm	±0.05 μm

V-508, dimensions in mm

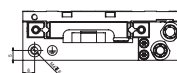
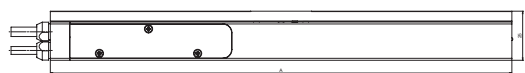
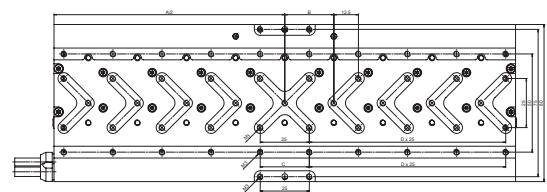
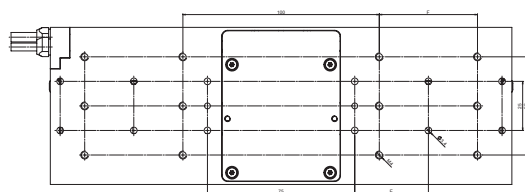

V-508.3xxxxx V-508.6xxxxx V-508.9xxxxx

	V-508.3xxxxx	V-508.6xxxxx	V-508.9xxxxx
Stroke	80	170	250
A	145	235	315
B	25	25	12,5
C	25	25	–
D	2	4	5
E	25	37,5	50
F	–	50	50

V-408 PIMag[®] Linear Stage

Inexpensive, with Linear Motor

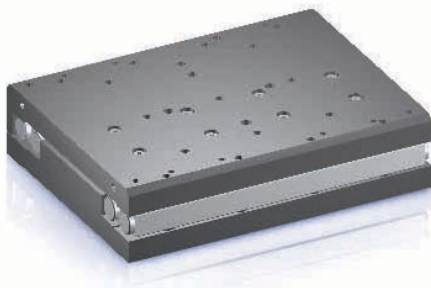

- Iron core 3-phase linear motor
- Crossed roller bearings for high load capacity
- Travel range 25 or 50 mm
- Minimum incremental motion 20 nm
- Bidirectional repeatability $\pm 0.1 \mu\text{m}$
- Compact design
- Low price

>> Direct Metrology
 >> PIMag[®] Magnetic Linear Motors

Technology Glossary page 76

Preliminary data	V-408	Unit	Tolerance
Min. incremental motion	20	nm	typ.
Bidirectional repeatability	± 0.1	μm	typ.
Straightness / flatness	± 4	μm	typ.
Velocity	25 mm: 1.1 50 mm: 1.5	m/s	max.
Load capacity in Z	80	N	max.

V-408, dimensions in mm

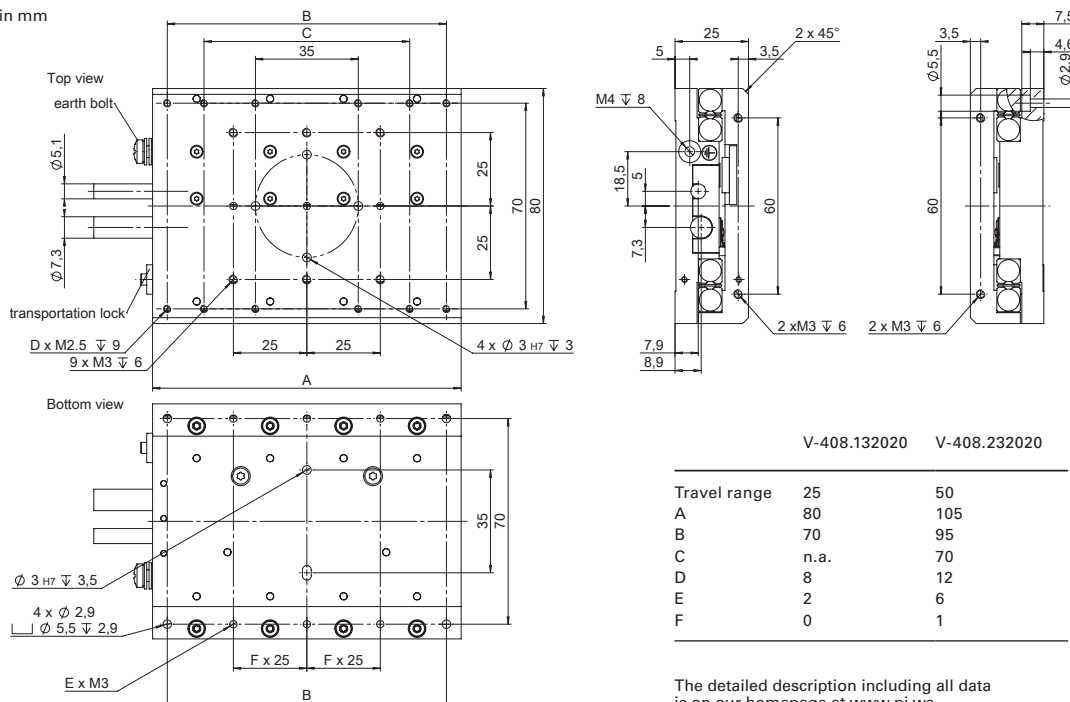

The detailed description including all data is on our homepage at www.pi.ws

V-412, V-418, V-423 High-Load Linear Stage

High Performance and Cost Efficiency



>> Direct Metrology
>> PIMag® Magnetic Linear Motors

Technology Glossary page 76

- Width 124 to 225 mm
- Travel range to 1 m
- Peak force to 720 N
- Incremental or absolute linear encoder, various resolutions
- Precision recirculating ball bearings, load capacity to 1000 N
- Covering strip on the side for protection against particle emission
- Versions with synchronous servo motor on request

Preliminary data	V-412.03	V-418.05	V-423.05	Unit	Tolerance
Travel range	52	102	102	mm	
Bidirectional repeatability	±0.3	±0.3	±0.3	µm	typ.
Minimum incremental motion	5	5	5	nm	typ.
Position accuracy, with error compensation	±1	±1	±1	µm	typ.
Straightness / flatness	±1.5	±2.5	±2.5	µm	typ.
Flatness	±2	±2.5	±2.5	µm	typ.
Velocity	2	2	2	m/s	max.
Load capacity in Z	400	450	1000	N	max.
Dimensions L x W x H	275 x 184 x 70	360 x 236 x 70		mm	

L-505 Compact Linear Stage

With DC or Stepper Motor

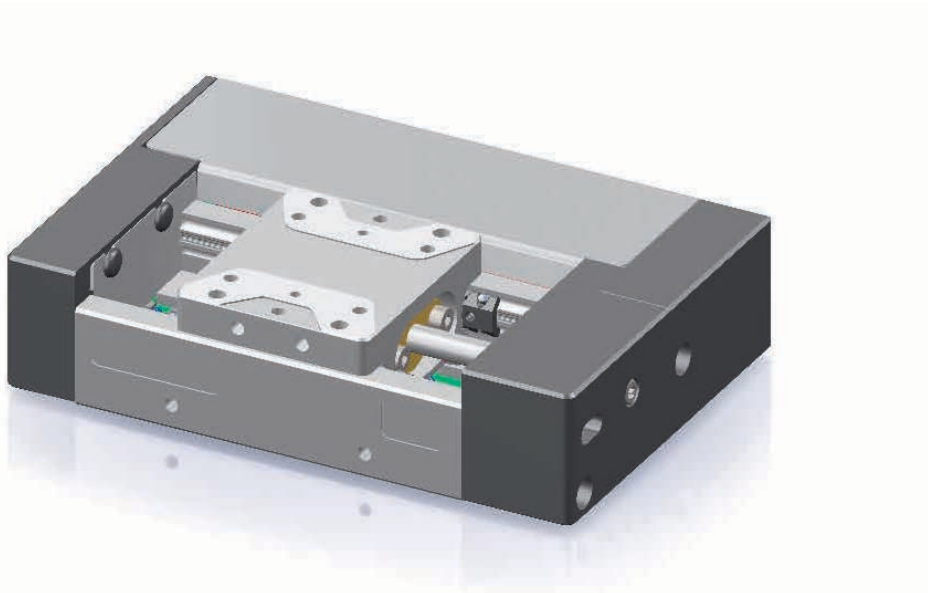

>> Direct Metrology
Technology Glossary page 76

- Travel ranges 13 or 26 mm
- Stepper motor or DC servo motor with and without gearhead
- Velocity to 5 mm/s
- Load capacity to 30 N
- Integrated reference point and limit switch
- Directly mountable XY combination
- For automation tasks
- Dimensions: 88 mm × 60 mm × 21 mm

Preliminary data	L-505.0x421xF	L-505.0x321xF	L-505.01421x	L-505.0x321x	Unit	Tolerance
Stages with DC motor	Linear stage with belt and DC gear motor	Linear stage with belt and DC motor	Linear stage with DC gear motor	Linear stage with DC motor		
Travel range	L-505.01: 13 L-505.02: 26	L-505.01: 13 L-505.02: 26	L-505.01: 13 L-505.02: 26	L-505.01: 13 L-505.02: 26	mm	
Integrated sensor	Incremental linear encoder	Incremental linear encoder	Incremental linear encoder	Incremental linear encoder		
Backlash	>2	>2	>2	>2	µm	
Velocity	1.5	10	1.5	15	mm/s	max.
Load capacity in z	30	30	30	30	N	max.

Preliminary data	L-505.0x42xxF	L-505.0x12xxF	L-505.0x12xx	Unit	Tolerance
Stages with stepper motor	Linear stage with belt and stepper motor with gearhead	Linear stage with belt and stepper motor	Linear stage with stepper motor		
Travel range	L-505.01: 13 L-505.02: 26	L-505.01: 13 L-505.02: 26	L-505.01: 13 L-505.02: 26	mm	
Integrated sensor	Incremental linear encoder	Incremental linear encoder (optional)	Incremental linear encoder (optional)		
Backlash	>2	>2	>2	µm	
Velocity	1	10	15	mm/s	max.
Load capacity in z	30	30	30	N	max.

The detailed description including all data is on our homepage at www.pi.ws

L-402 Miniature Linear Stage

With DC or Stepper Motor

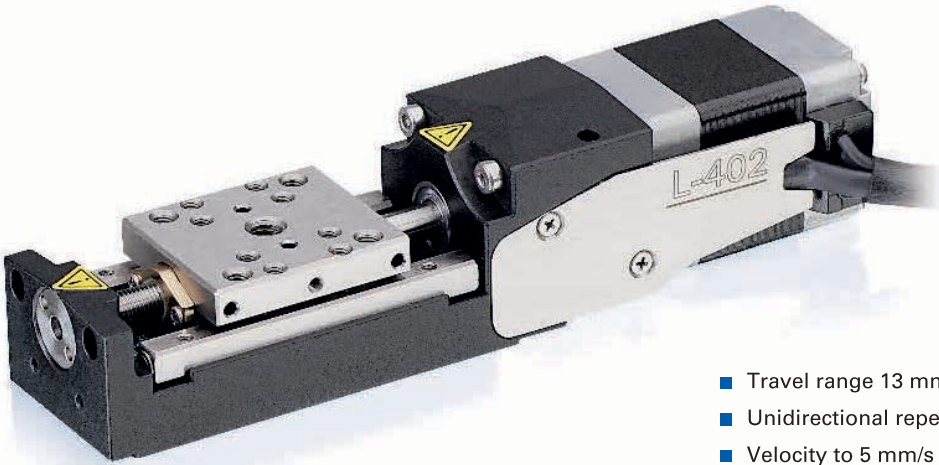

- Travel range 13 mm
- Unidirectional repeatability to 0.5 μm
- Velocity to 5 mm/s
- Load capacity to 1 kg
- Directly mountable XY and XYZ combinations
- Integrated reference point and limit switch

L-402.10DD, dimensions in mm

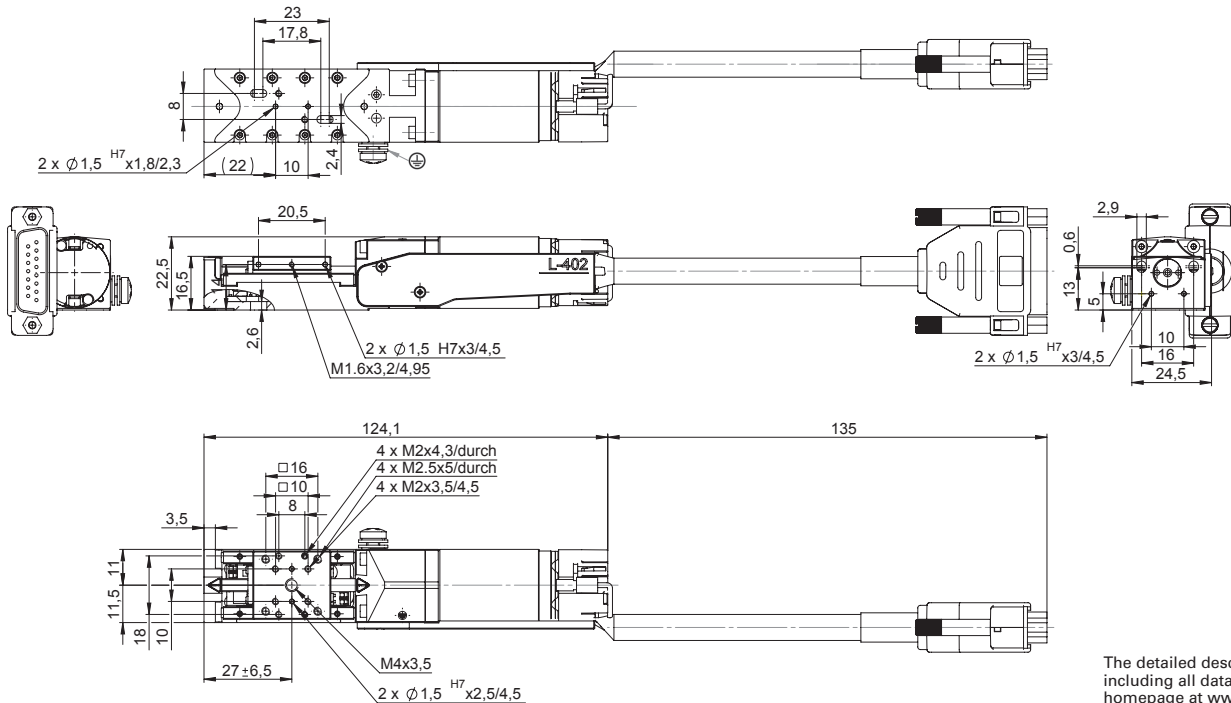

The detailed description including all data is on our homepage at www.pi.ws

	L-402.10DD	L-402.10SD	Unit	Tolerance
Motion and positioning				
Travel range	13	13	mm	
Integrated sensor	Rotary encoder	–		
Design resolution	0.012	2.5 (full step)	µm	
Minimum incremental motion	1	0.5	µm	
Backlash	2	2	µm	
Unidirectional repeatability	1	0.5	µm	
Pitch	±175	±175	µrad	
Yaw	±125	±125		
Velocity	5	5	mm/s	max.
Mechanical properties				
Drive screw	Leadscrew	Leadscrew		
Spindle pitch	0.5	0.5	mm	
Load capacity	10	10	N	max.
Push/pull force	10	10	N	max.
Holding force	10	10	N	max.
Lateral force	5	5	N	max.
Drive properties				
Motor Type	DC motor	2-phase stepper motor*		
Operating voltage	0 to ±12		V	
Current consumption	0.46**		A	
Reference and limit switches	optical	optical		
Miscellaneous				
Operating temperature range	–20 to 65	–20 to 65	°C	
Material	Aluminum, anodized, stainless steel	Aluminum, anodized, stainless steel		
Mass	0.2	0.15	kg	
Cable length	0.135	0.25		±10
Connector	Sub-D 15, incl. encoder driver	Sub-D 15		
Recommended controller/driver	C-863 (single axis) C-884 (up to 4 axes)	C-663 (single axis)		

L-402.10SD, dimensions in mm

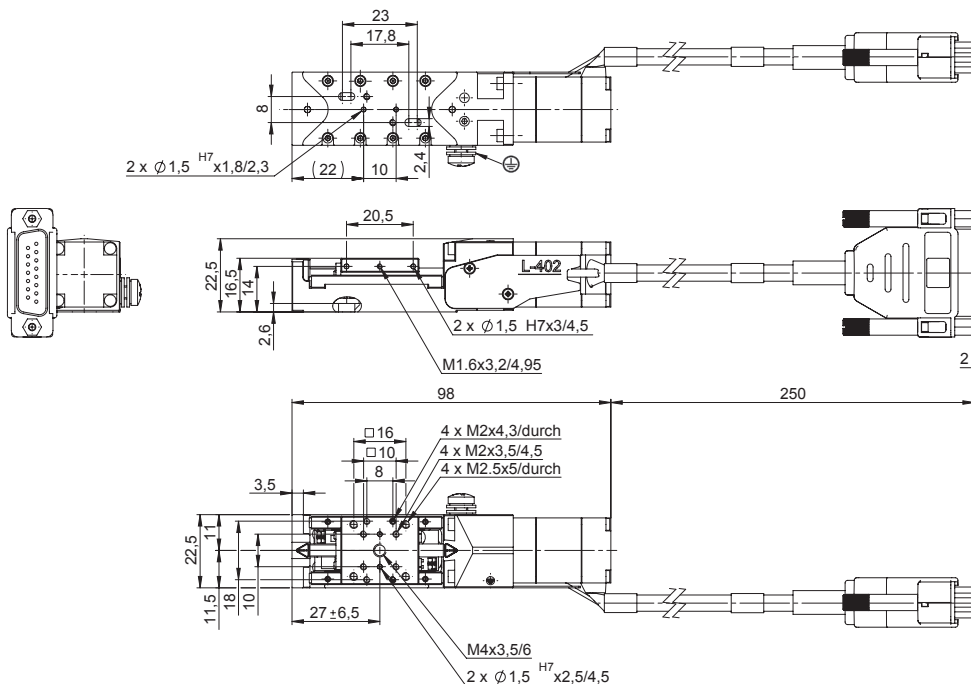

* 24 V chopper voltage, max.
0.25 A/phase; 200 full steps/rev
** thermally limited average current
All cables required for operation with the recommended controller are included in the scope of delivery. 3 m extension cable included.
Ask about custom designs!

L-220 High-Resolution Linear Actuator

Suitable for a High Number of Cycles



>> Vacuum-Compatible Versions
 Technology Glossary page 76

- Forces of up to 125 N
- Travel ranges 13 to 77 mm (1/2" to 3")
- MTBF >10,000 h
- DC or 2-phase stepper motors
- 0.5 m cable length plus 3 m extension incl.

	L-220.x0DG	L-220.x0SG	Unit	Tolerance
Minimum incremental motion	0.1	0.1	µm	typ.
Backlash	1.5	1.5	µm	typ.
Velocity	3.5	0.8	mm/s	max.
Push/pull force	125	125	N	max.
Motor Type	DC motor with gearhead	2-phase stepper motor with gearhead	N	max.

L-220, dimensions in mm

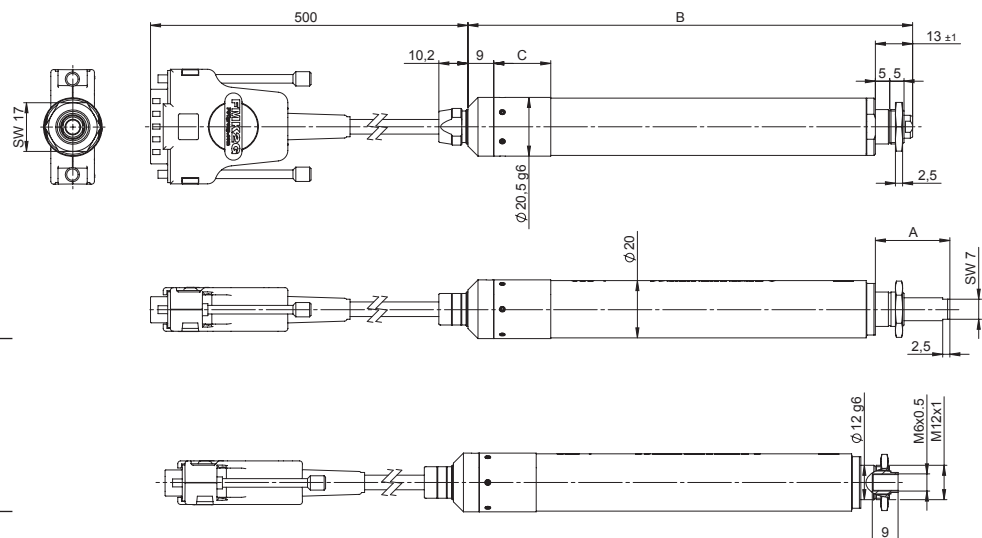

	Travel	A	B	C
L-220.10SG	13	26	148,3	13
L-220.10DG	13	26	155,2	19,9
L-220.20SG	26	39	161,5	13
L-220.20DG	26	39	168,4	19,9
L-220.50SG	52	65	186,6	13
L-220.50DG	52	65	193,5	19,9
L-220.70SG	77	90	211,6	13
L-220.70DG	77	90	218,5	19,9

L-310 Precision Z Stage

Compact Multi-Axis Combinations with Linear and Rotation Stages

- Travel range 26 mm (1")
- High-resolution encoder
- Zero-play ball screws
- MTBF 10000 h
- Self locking to 10 kg
- DC or 2-phase stepper motors
- Noncontact limit and reference point switches



>> Direct Metrology

Technology Glossary page 76

	L-310.20SD	L-310.2ASD	L-310.20AD	L-310.24AD	Unit	Tolerance
Integrated sensor	–	Linear encoder	Rotary encoder	Linear encoder		
Minimum incremental motion	0.2	0.1	0.1	0.5	µm	typ.
Unidirectional repeatability	0.2	0.1	0.5	0.05	µm	typ.
Load capacity	55	55	30	30	N	max.
MotorType	2-phase stepper motor	2-phase stepper motor	DC motor with PWM control	DC motor with PWM control		

L-310, dimensions in mm

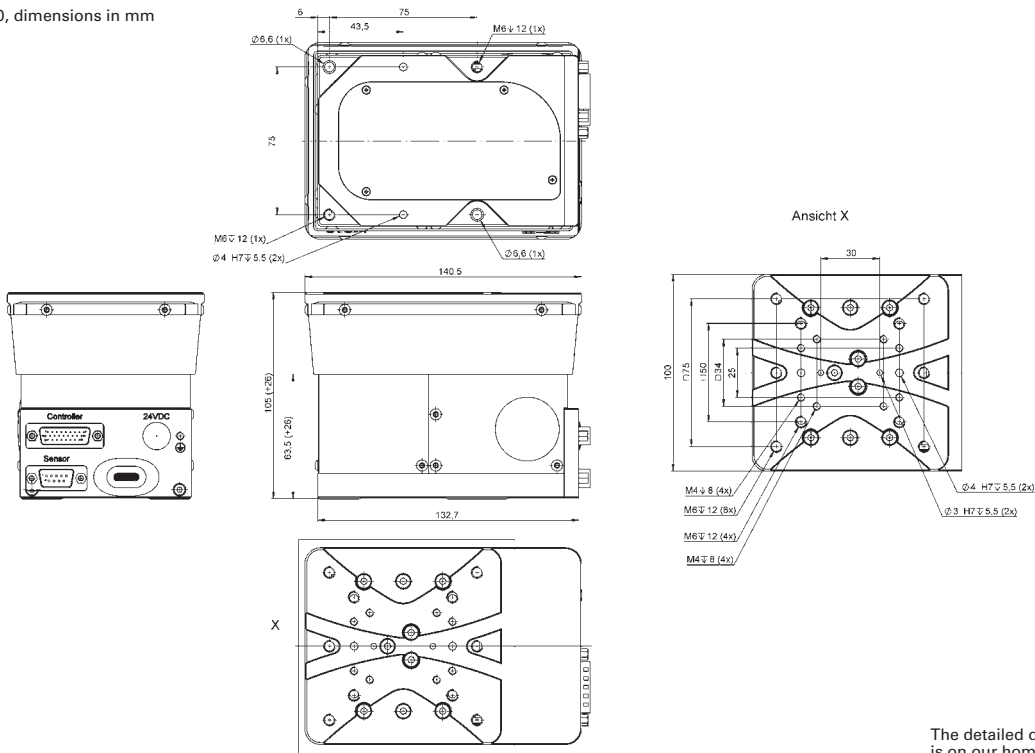

The detailed description including all data is on our homepage at www.pi.ws

L-611 Precision Rotation Stage

High Travel Accuracy

- Unlimited travel range
- Ultrahigh resolution
- Maximum velocity 200°/s
- Load capacity 100 N
- Direction-sensing reference point switch
- Individual measurement logs for wobble, axial, and radial creep available on request



>> Vacuum-Compatible Versions

Technology Glossary page 76

	L-611.90SD	L-611.9ASD*	L-611.90AD	L-611.94AD*	Unit	Tolerance
Minimum incremental motion	0.34 (0.00002)	0.7 (0.00004)*	35 (0.002)	0.7 (0.00004)*	μrad (°)	typ.
Bidirectional repeatability	–	±3.5 (±0.0002)	±175 (±0.01)	±3.5 (±0.0002)	μrad (°)	
Velocity	50	50	200	200	°/s	max.
Motor Type	2-phase stepper motor***	2-phase stepper motor***	DC motor with PWM control, rotary encoder	DC motor with PWM control		

L-611.90SD and L-611.9ASD
(rotation stage, dimensions in mm)

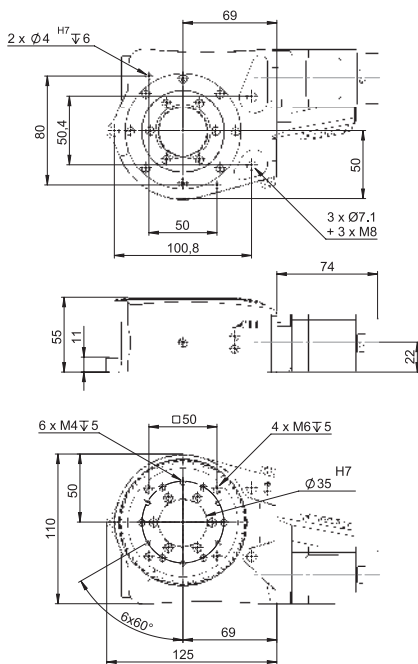

L-611.90AD and L-611.94AD
rotation stages, dimensions in mm

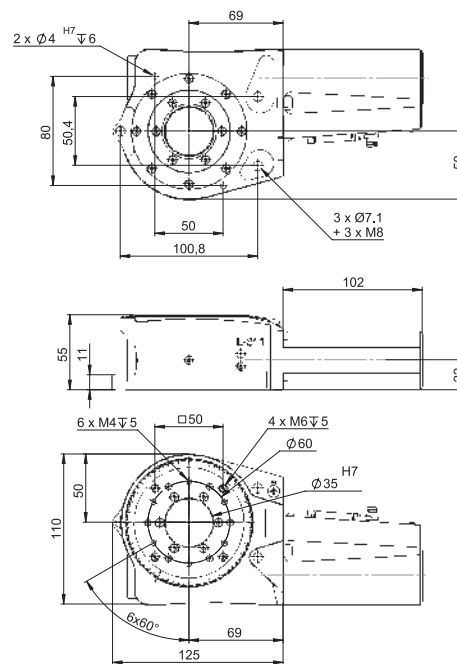

* With integrated angle measuring system
*** 2-phase stepper motor, 200 full steps/rev., max. 1.2 A/phase

The detailed description including all data is on our homepage at www.pi.ws

L-731 Precision XY Stage

High Travel Accuracy and Stability



- Travel range 205 mm × 205 mm (8")
- 2-phase stepper motors
- Unidirectional repeatability to 0.25 μm
- Velocity to 45 mm/s
- Incremental encoder with 10 nm resolution

L-731, dimensions in mm

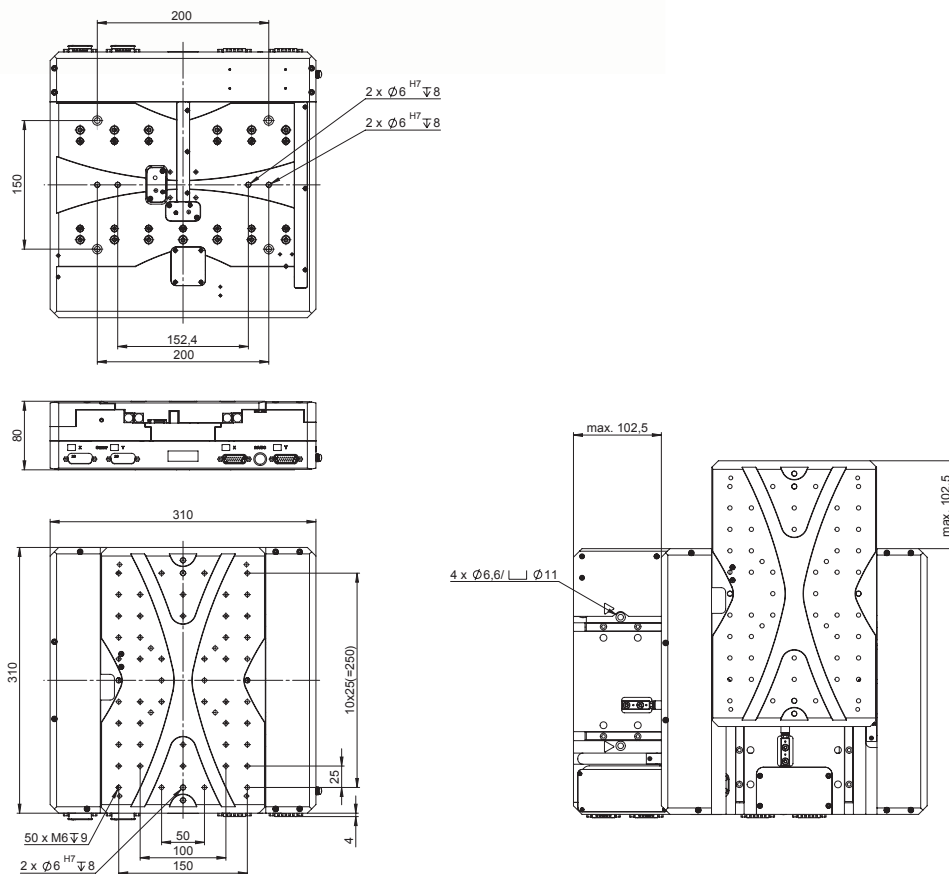

	L-731.40SD	L-731.44SD	L-731.4ASD	Unit	Tolerance
	XY stage with stepper motor	XY stage with stepper motor and linear encoder (direct position measurement)	XY stage with stepper motor and linear encoder (direct position measurement)		
Motion and positioning					
Active axes	X,Y	X,Y	X,Y		
Travel range	205 × 205	205 × 205	205 × 205	mm	
Integrated sensor	–	Incremental linear encoder	Incremental linear encoder		
Sensor resolution	–	10	10*	nm	
Sensor signal period	–	–	20	µm	
Minimum incremental motion	1.25	0.05	0.05	µm	typ.
Unidirectional repeatability	0.5	0.25	0.25	µm	typ.
Bidirectional repeatability	±1	±0.5	±0.5	µm	typ.
Backlash	1	–	–	µm	
Pitch	±125	±125	±125	µrad	typ.
Yaw	±50	±50	±50	µrad	typ.
Straightness / flatness	±3	±3	±3	µm	typ.
Velocity	45	45	45	mm/s	max.
Reference and limit switches	optical	optical	optical		
Mechanical properties					
Load capacity	50	50	50	N	
Permissible torque in θ_x, θ_y	125	125	125	N·m	
Permissible torque in θ_z	125	125	125	N·m	
Moved mass in X	12	12	12	kg	
Moved mass in Y	3.5	3.5	3.5	kg	
Overall mass	16	16	16	kg	
Guiding	Crossed roller guide with anti-creep system	Crossed roller guide with anti-creep system	Crossed roller guide with anti-creep system		
Drive properties					
Motor Type	2-phase stepper motor	2-phase stepper motor	2-phase stepper motor		
Operating voltage	24	24	24	V	
Motor power	5	5	5	W	nominal
Miscellaneous					
Operating temperature range	10 to 50	10 to 50	10 to 50	°C	
Humidity	20 – -90 % rel., not condensing	20 – -90 % rel., not condensing	20 – -90 % rel., not condensing		
Material	Aluminum, black anodized	Aluminum, black anodized	Aluminum, black anodized		
Connection	Motor connection: 2x HD Sub-D 26 (m)	Motor connection: 2 × HD Sub-D 26 (m) Sensor connection: 2 × Sub-D 15 (f)	Motor connection: 2 × HD Sub-D 26 (m) Sensor connection: 2 × Sub-D 15 (f)		
Recommended controller	2 × C-663 Mercury Step Motion Controller, SMC Hydra Motion Controller for 2 axes	2 × C-663 Mercury Step Motion Controller	SMC Hydra Motion Controller for 2 axes		

* with SMC Hydra. Other interpolation factors available as an option.
All cables required for operation with the recommended controller are included in the scope of delivery.
Cable for connecting to other controllers can be ordered as accessory.

A-110 Pliglide LC Linear Stage with Air Bearings

High-Performance Nanopositioning System with a good Price



- >> Pliglide Air Bearing Technology
- >> PIMag® Magnetic Linear Motors

Technology Glossary page 76

- Ideal for scanning applications or high-precision positioning
- Clean room compatible
- Table size 160 mm x 200 mm
- Travel ranges to 400 mm
- Load capacity to 100 N
- XY setups and individual configurations

For more Pliglide Linear Stages visit www.pi.ws:

- Compact size: A-121 series
- Higher payload: A-123 series

The detailed description including all data is on our homepage at www.pi.ws

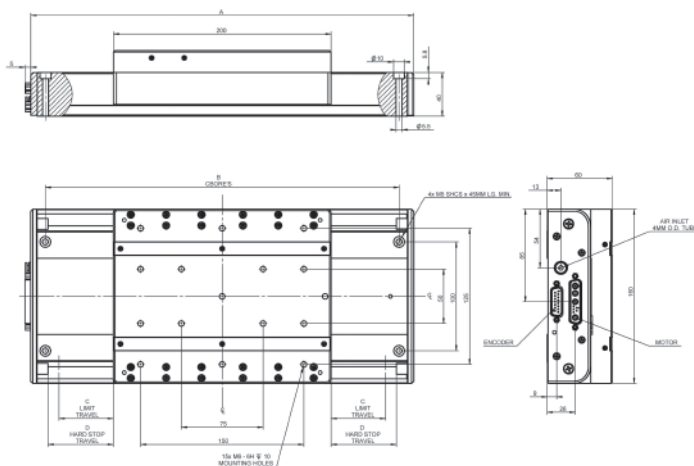

A-110.050 and A-110.100, dimensions in mm

	A	B	C	D
A-110.050	302	275	25	35
A-110.100	352	325	50	60

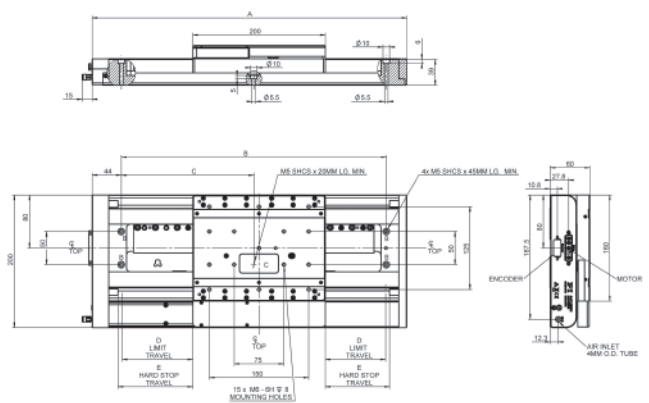

A-110.200, A-110.300 and A-110.400, dimensions in mm

	A	B	C	D	E
A-110.200	475	400	200	102	105
A-110.300	575	500	250	152	155
A-110.400	675	600	300	202	205

	A-110.050xx	A-110.100xx	A-110.200xx	A-110.300xx	A-110.400xx	Unit	Tolerance
Motion and positioning							
Active axes	X	X	X	X	X		
Travel range	50	100	200	300	400	mm	
Pitch*	10	20	30	40	50	μrad	max.
Yaw*	10	20	30	40	50	μrad	max.
Straightness / Flatness*	±1	±1	±1.5	±2	±2.5	μm	max.
Straightness / Flatness per 10 mm travel range*	±10	±10	±10	±10	±10	nm	max.
Velocity, unloaded**	0.5	0.5	1	1	1	m/s	max.
Acceleration, unloaded**	10	10	30	30	30	m/s ²	max.
Mechanical properties							
Load capacity in z***	100	100	100	100	100	N	max.
Moved mass	2.5	2.5	2.6	2.6	2.6	kg	
Overall mass	6.3	7.5	11	12	14	kg	
Guide type	Air bearings	Air bearings	Air bearings	Air bearings	Air bearings		
Drive properties							
Drive type	Linear motor, ironless, 3-phase	Linear motor, ironless, 3-phase	Linear motor, ironless, 3-phase	Linear motor, ironless, 3-phase	Linear motor, ironless, 3-phase		
Intermediate circuit voltage, effective	48, nom. 60, max.	48, nom. 60, max.	48, nom. 60, max.	48, nom. 60, max.	48, nom. 60, max.	VDC	
Peak force	25	25	85	85	85	N	typ.
Nominal force	9.2	9.2	39	39	39	N	typ.
Force constant, effective	4.2	4.2	12.3	12.3	12.3	N/A	typ.
Resistance phase-phase	8.2	8.2	3.6	3.6	3.6	Ω	typ.
Inductivity phase-phase	2.7	2.7	1.24	1.24	1.24	mH	typ.
Back EMF phase-phase	4.2	4.2	10.1	10.1	10.1	V·s/m	max.
Cabling	Internal, no moving cable	Internal, no moving cable	External, moving cable	External, moving cable	External, moving cable		

	A-110.xxxA	A-110.xxxB	A-110.xxxC
Integrated Sensor	Incremental linear encoder	Absolute Encoder	Incremental linear encoder
Sensor signal	Sin/cos, 1 V peak-peak, 20 μm signal period	BiSS-C	A/B quadrature, TTL
Sensor resolution	controller dependent	1 nm	50 nm
Bidirectional repeatability	controller dependent	±0.5 μm	±0.5 μm
Accuracy, uncompensated #	A-110.050: ±1 μm	A-110.050: ±1.5 μm	A-110.050: ±1 μm
	A-110.100: ±1.5 μm	A-110.100: ±1.5 μm	A-110.100: ±1.5 μm
	A-110.200: ±2 μm	A-110.200: ±1.5 μm	A-110.200: ±2 μm
	A-110.300: ±3 μm	A-110.300: ±1.5 μm	A-110.300: ±3 μm
	A-110.400: ±4 μm	A-110.400: ±1.5 μm	A-110.400: ±4 μm
Accuracy, with error compensation #	A-110.050: ±1 μm	A-110.050: ±0.5 μm	A-110.050: ±1 μm
	A-110.100: ±1 μm	A-110.100: ±0.5 μm	A-110.100: ±1 μm
	A-110.200: ±1 μm	A-110.200: ±0.5 μm	A-110.200: ±1 μm
	A-110.300: ±1.5 μm	A-110.300: ±0.5 μm	A-110.300: ±1.5 μm
	A-110.400: ±1.5 μm	A-110.400: ±0.5 μm	A-110.400: ±1.5 μm

A-110	
Operating pressure ##	60 to 70 psi (415 to 485 kPa)
Air consumption	<1.0 SCFM (28 SLPM)
Air quality	Clean (filtered to 1.0 μm or better) – ISO 8573-1 Class 1
	Oil-free – ISO 8573-1 Class 1
	Dry (–15 °C dew point) – ISO 8573-1 Class 3
Materials	Hardcoat aluminum, stainless steel fasteners

* Dependent on the flatness of the surface, on which the stage is mounted.

** Can be limited by the payload, controller or drive.

*** Assumes payload CG is centered no more than 50 mm above the stage table. Stage is designed for horizontal operation only.

Improved accuracy can be obtained with controller-based error compensation. Accuracy values assume short-term time duration and do not consider the long-term effects of thermal drift on the stage.

To protect the stage against damage, it is recommended to connect an air pressure sensor to the Motion-Stop input of the controller.

A-141 Pliglide MB Miniature Linear Air Bearing Stage

High Performance, Cleanroom Compatible, Customizable



>> Pliglide Air Bearing Technology

Technology Glossary page 76

- Size of the motion platform 57 mm x 83 mm
- Low profile 38 mm
- Travel ranges to 40 mm
- Load capacity to 3.5 kg
- Non-contact fully preloaded air bearings
- Ironless cog-free linear motor
- Integral optical linear encoder
- Resolution to 20 nm
- Velocity to 0.5 m/sec
- Acceleration to 7.5 m/s²

Large range of accessories

- Air preparation kits
- Single or multi-axis motion controllers and servo drives
- XY stacks and custom configurations with precision alignment
- Counterbalance options for vertical (Z) orientations
- Customizations available
- Granite bases and vibration isolation systems

A-141.040, dimensions in mm

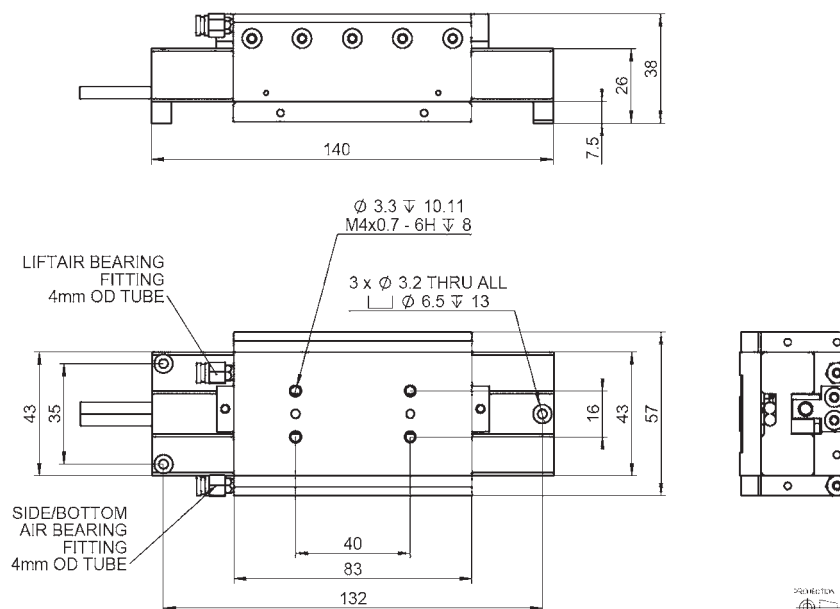

The detailed description including all data is on our homepage at www.pi.ws

A-141.040B1

Travel	40 mm
Drive type	Brushless ironless linear servo motor, 3-phase
Feedback system	Non-contact optical linear encoder with travel limits and home index
Intermediate circuit voltage, effective	48 VDC nominal, 80 VDC max
Force constant, effective	2.1 N/A
Nominal force	0.58 N
Peak force	2.3 N
Back EMF phase-phase	0.7 V·s/m
Resistance phase-phase	22.4 Ω
Inductivity phase-phase	1.0 mH
Maximum velocity (1)	Up to 0.5 m/s
Maximum acceleration (1) (unloaded)	Up to 7.5 m/s ²
Load capacity in z (2)	3.5 kg
Accuracy (3) (uncompensated)	±2.0 μm
Accuracy (3) (with error compensation)	±0.5 μm
Repeatability	±0.2 μm
Encoder resolution (4)	20 nm
Straightness / flatness (5)	<1μm TIR over full travel
Pitch / yaw (5)	<5 μrad over full travel
Overall mass	0.6 kg
Moving mass	0.3 kg
Cabling	Internal, non-moving
Operating pressure (6)	65±5 psi (450±35 kPa)
Air consumption	<1.0 SCFM (28 SLPM)
Air quality	Clean (filtered to 1.0 μm or better) – ISO 8573-1 Class 1; Oil-free – ISO 8573-1 Class 1; Dry (-15 °C dew point) – ISO 8573-1 Class 3
Materials	Hardcoat aluminum, stainless steel fasteners

- (1) Maximum velocity and acceleration based on unloaded stage capability, may be limited by payload, controller, or drive performance.
 (2) Assumes payload CG is centered no more than 50mm above the stage table. Stage is designed for horizontal operation only.
 (3) Improved accuracy can be obtained with controller-based error compensation. Accuracy values assume short-term time duration and do not consider the long-term effects of thermal drift on the stage.
 (4) Encoder resolution depends on encoder option chosen. Resolution will impact repeatability specification.
 (5) Dependent on the flatness of the surface to which the stage is mounted.
 (6) To protect stage from damage, an under-pressure air sensor tied to the controller E-stop input is recommended.

A-62x Plglide RM Rotation Stage with Air Bearing

Friction-Free, Ideal for Indexing, Positioning, Scanning, Measuring Technology



- Cleanroom compatible
- Table diameters from 50 mm to 300 mm
- Load capacity up to 4170 N
- Eccentricity and flatness <200 nm
- 3-phase torque motor
- Can be mounted vertically or horizontally
- Optional absolute-measuring or incremental angle measuring system
- Non-motorized air bearings available

>> Plglide Air Bearing Technology

Technology Glossary page 76

A-621.025xx, dimensions in mm

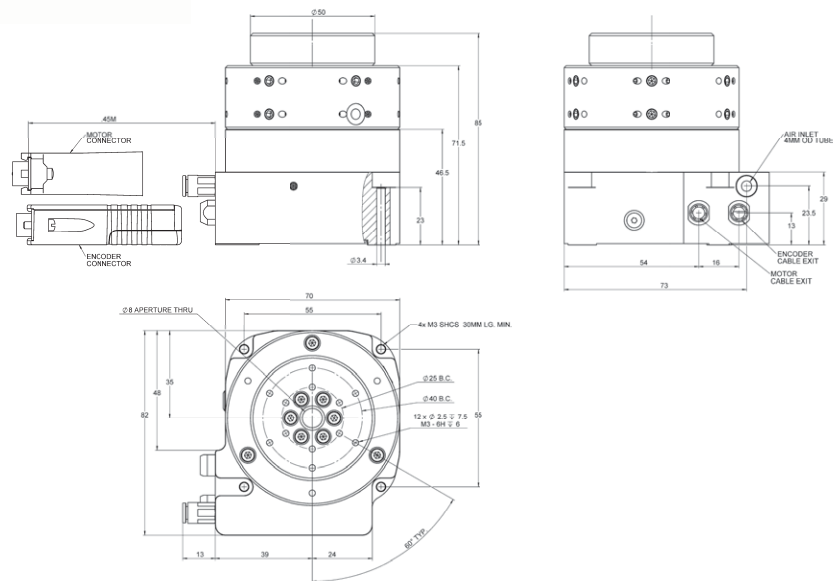

A-627.075xx, dimensions in mm

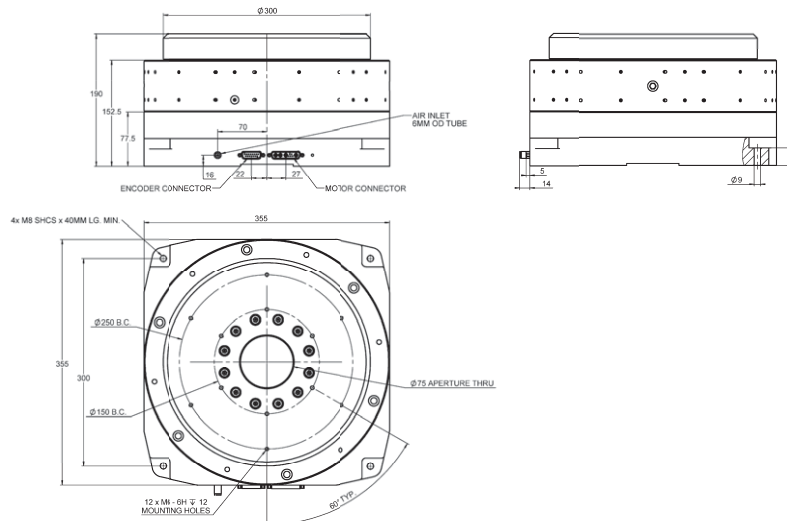

	A-621.025	A-623.025	A-623.050	A-624.050	A-627.075	Unit	Tolerance
Motion and positioning							
Travel range	Unlimited, >360°		Unlimited, >360°				
Table Diameter	50	100	100	150	300	mm	
Bearing length	25	25	50	50	75	mm	
Eccentricity	300	200	200	100	75	nm	max.
Flatness*	150	100	100	75	50	nm	max.
Wobble*	5	3	3	2	1	μrad	max.
Mechanical properties							
Load capacity, axial	134	536	536	1206	4244	N	max.
Load capacity, radial	57	115	229	344	1203	N	max.
Load torque M _{x,y}	0.57	1.7	4.52	22.6	141.3	N·m	max.
Axial stiffness	26	96	96	210	788	N/μm	
Radial stiffness	8	18	35	64	204	N/μm	
Moment of inertia	125	1485	1530	8790	210850	kg·mm ²	
Moved mass	0.4	1.2	1.4	3.2	21.5	kg	typ.
Overall mass	1.2	3.1	4.5	8.6	50	kg	
Guide type	Air bearing	Air bearing	Air bearing	Air bearing	Air bearing		
Drive properties							
Drive type	Torque motor, 3-phase, brushless, ironless, slotless						
Intermediate circuit voltage, effective	48, nominal 80, max.	48, nominal 80, max.	48, nominal 80, max.	48, nominal 80, max.	48, nominal 80, max.	V DC	max.
Peak torque	0.21	2.1	2.1	4.71	8.46	N·m	typ.
Nominal torque	0.07	0.7	0.7	1.57	2.82	N·m	typ.
Force constant, effective	0.03	0.26	0.26	0.59	0.61	N·m/A	typ.
Resistance phase-phase	2.7	4.2	4.2	6.7	4.5	Ω	
Inductivity phase-phase	0.1	0.4	0.4	0.9	0.6	mH	
Back EMF phase-phase	4.1	31.8	31.8	71	74	V/kRPM	max.

	A-62x.xxxAx	A-62x.xxxBx	A-62x.xxxCx
Integrated sensor	Incremental angle measuring system	Absolute-measuring angle measuring system	Incremental angle measuring system
Sensor signal	Sin/cos, 1 V peak-peak	BiSS-C	A/B quadrature, TTL
Lines / revolution	A-621: 8192 A-624: 23600 A-623: 15744 A-627: 47200	–	A-621: 8192 A-624: 23600 A-623: 15744 A-627: 47200
Velocity**	A-621: 2500 rpm max. A-623: 1200 rpm max. A-624: 600 rpm max. A-627: 500 rpm max.	A-621: 2500 rpm max. A-623: 1200 rpm max. A-624: 600 rpm max. A-627: 500 rpm max.	A-621: 550 rpm max.*** A-623: 300 rpm max.*** A-624: 175 rpm max.*** A-627: 75 rpm max.***
Sensor resolution	A-621: 0.19 μrad**** A-623: 0.1 μrad**** A-624: 0.06 μrad**** A-627: 0.03 μrad****	A-621: 0.0015 μrad A-623: 0.0015 μrad A-624: 0.0015 μrad A-627: 0.0015 μrad	A-621: 1.94 μrad# A-623: 1.02 μrad# A-624: 0.68 μrad# A-627: 0.33 μrad#
Bidirectional repeatability	±4 μrad	±4 μrad	±4 μrad
Accuracy, with error compensation##	±8 μrad	±8 μrad	±8 μrad
Reference point switch	1 / revolution, differential pulse over one sensor signal period, 1 V peak-peak	–	1 / revolution, one count over one step of the encoder, synchronized to output signal

A-62x	
Operating pressure###	75 to 85 psi (515 to 585 kPa)
Air consumption	<2 SCFM (56 SLPM)
Air quality	Clean (filtered to 1.0 μm or better) – ISO 8573 1 Class 1 / Oil free – ISO 8573 1 Class 1 Dry (–15 °C dew point) – ISO 8573 1 Class 3
Materials####	Hardcoat aluminum, stainless steel fasteners

* Depending on the quality of the underlying surface, the payload, orientation, and forces that act on the stage from the outside. Please contact PI for application-specific parameters. The specified values are static (no rotary motion during measuring) and without load.

** Can be limited by imbalance of the payload or the controller and the drive.

*** Assumes a sampling rate of 50 MHz.

**** Assumes 4096-fold interpolation. Contact PI for the use of other factors.

Uses 400-fold interpolation. Alternative digital encoder resolutions on request. Please contact PI for a quote.

The specified values are based on error compensation controlled by the controller. The stage must be ordered with a controller from PI to reach these values. Accuracy values assume short-term time duration and do not consider the long-term effects of thermal drift on the stage.

To protect the stage against damage, it is recommended to connect an air pressure sensor to the Motion-Stop input of the controller.

Customer-specific materials such as rust-free steel on request. Please contact PI for a quote.

Solutions for Motion Centric Industrial Automation

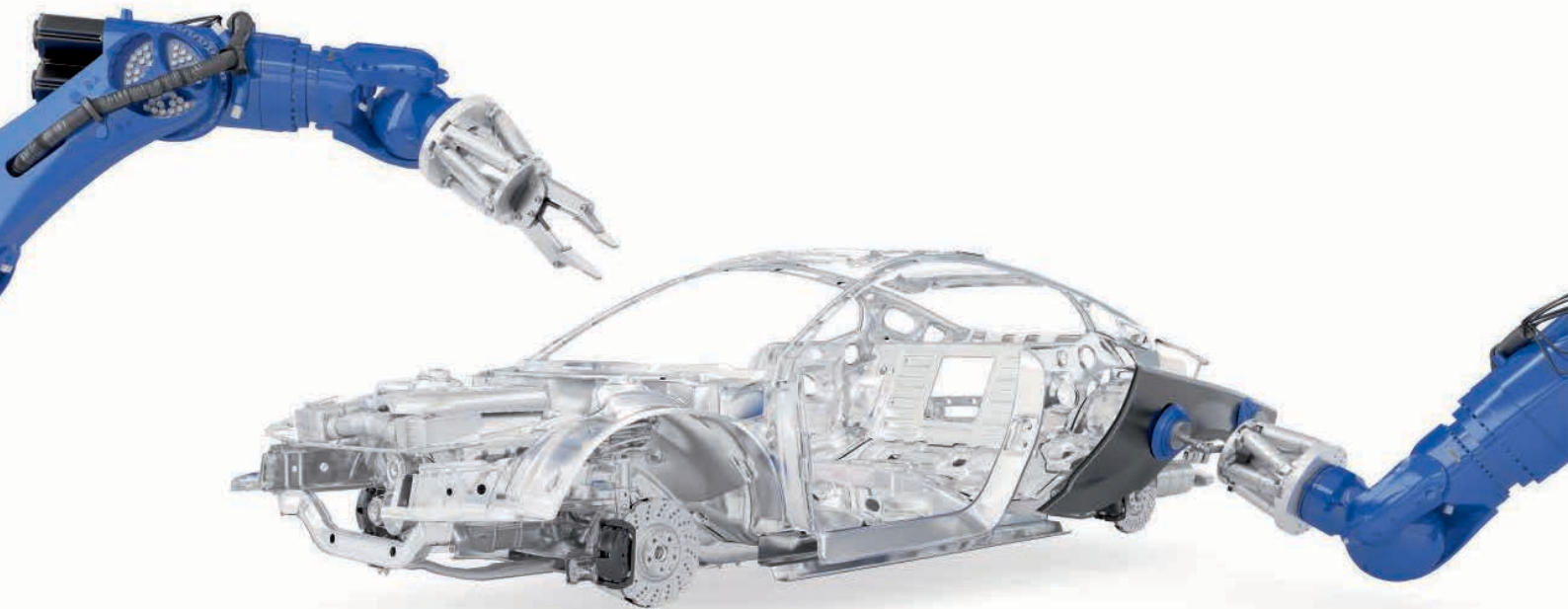

Positioning and motion tasks in industrial automation such as those in assembly, semiconductor manufacturing, mechanical engineering, laser material processing, inspection systems or in additive manufacturing demand solutions that need to be robust and reliable. Submicrometer accuracy, exact position reproducibility, high dynamics, and throughput are just as essential. This is particularly the case with industry 4.0 where safety and simple networking options play an important role.

SMARTER MOTION AND POSITIONING

What makes a positioner and motion solution smart? What functions and features must a high-performance control solution offer to make smart motion and positioning possible? PI has identified the following list of basic requirements that make it possible to offer solutions for industrial applications that fulfill the high demands for precision and dynamics irrespective of the number of motion axes.

- Functional safety
- Communication via fieldbus interfaces
- Autotuning
- Synchronization of the individual axes in the system
- Multidimensional motion profiles
- 3-DOF compensation of the position error
- Yaw compensation for gantry solutions
- Suppression of system oscillation
- Robust control behavior
- Easy integration into the higher-level automation environment

COMPLETE SOLUTIONS FOR HIGH-THROUGHPUT AND HIGH-PRECISION MULTI-AXIS APPLICATIONS

Those requirements can only be fulfilled when the mechanics, drive technology, and control electronics of the positioning system are perfectly matched to each other.

A solution from a single-source supplier does not just offer the customer sophisticated positioning technology and high-performance control solutions, but also faster start-up and high flexibility when implementing new requirements.

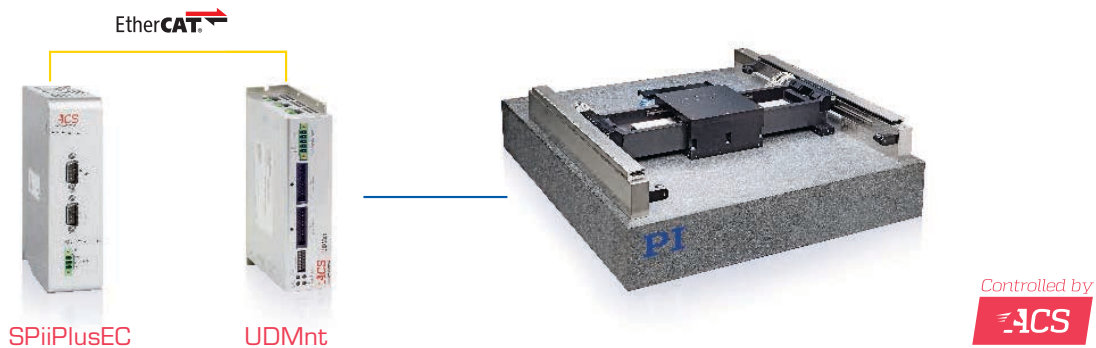

HIGH-PERFORMANCE MOTION CONTROL SYSTEMS

ACS Motion Control offers distributed-architecture motion control systems, completely modular, with components organized over three levels: The first level is the user interface. This is basically the host software and allows communication with the motion system.

The devices on the second level are called motion controllers. The motion controller is responsible for communication with the host software and also takes care of everything related to profile generation, trajectory, macros, diagnostics, and so on. The position commands are sent to the universal drive modules on the third level via an EtherCAT real-time network. In some products, the motion controller, the drives, and the power supplies are integrated into one housing. These products are called control modules.

The universal drive modules on the third level include the digital servo processor (DSP). It performs the servo positioning of the axes. The drive modules power and actuate the motors, handle the feedback devices, manage the I/Os, and analyze the sensor signals for closed-loop positioning control.

Overview of Available Modules

PI offers complete systems that implement the ACS motion control solutions

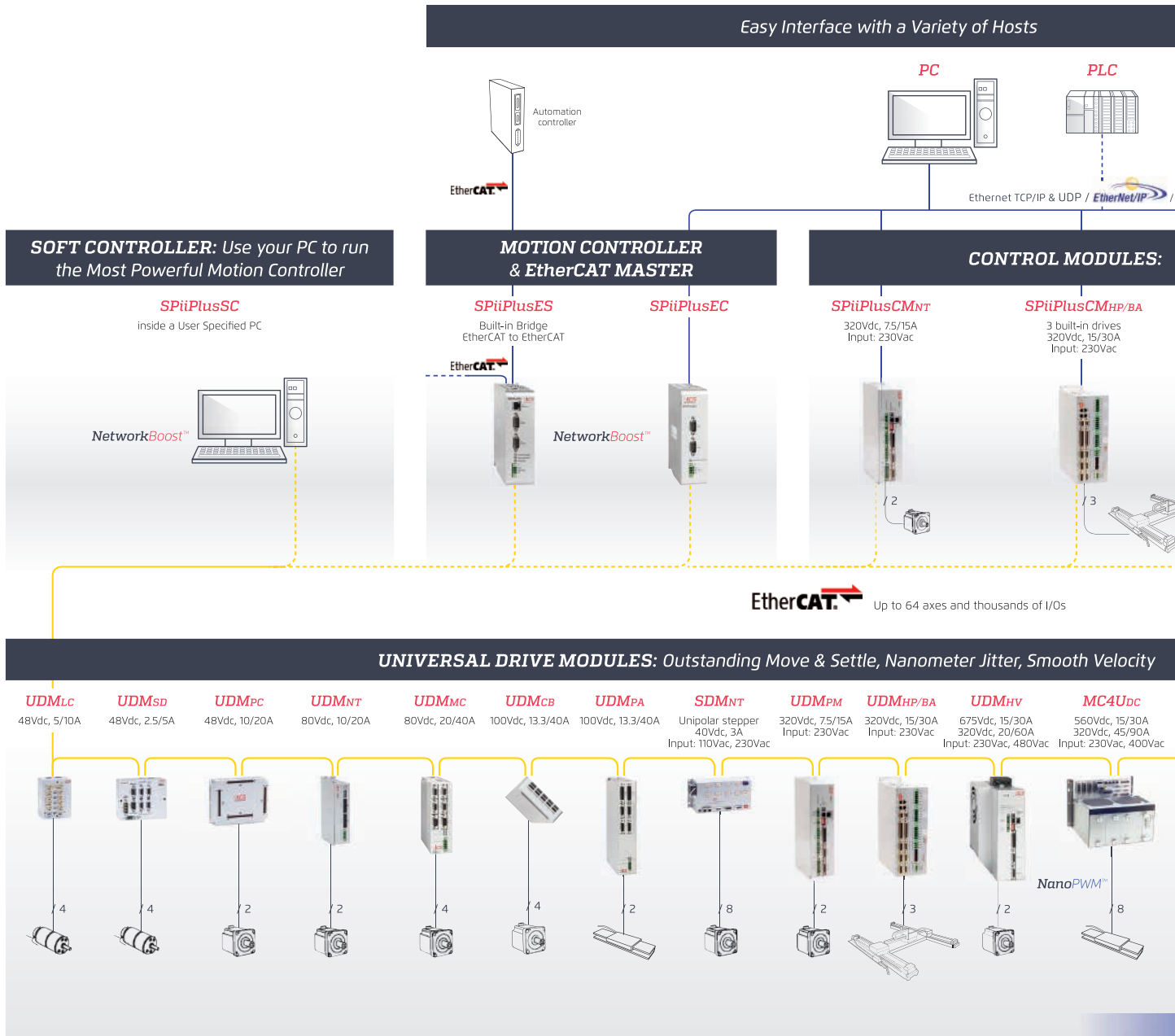

EtherCAT® is registered trademark and patented technology, licensed by bechhoff automation GmbH, germany

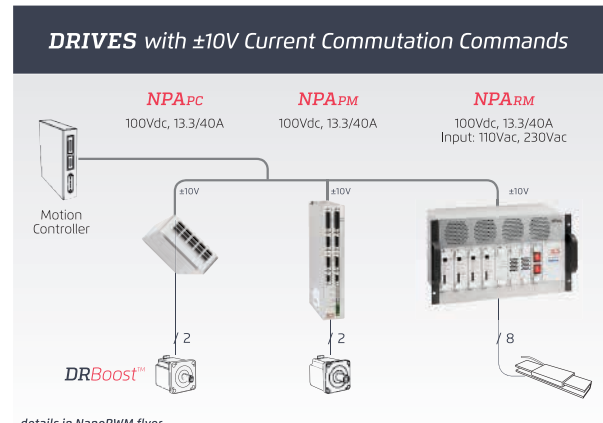
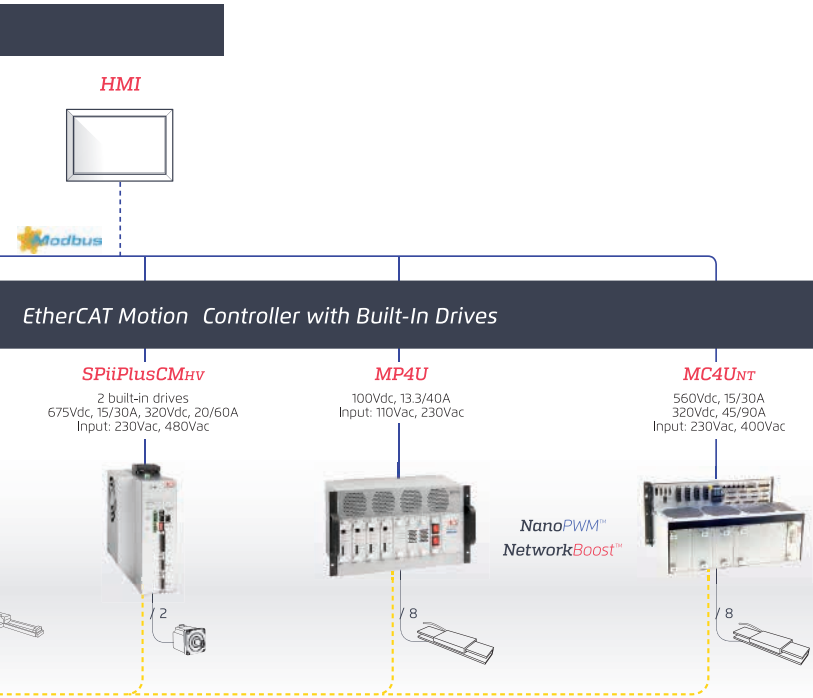

NanoPWM™

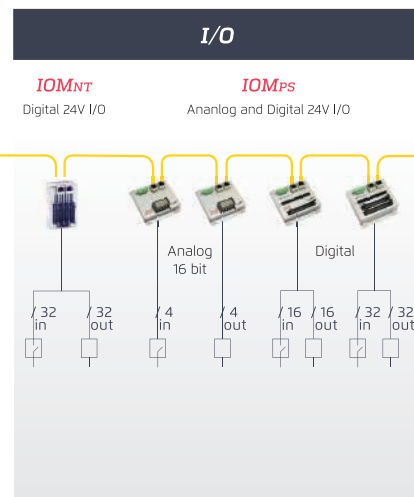
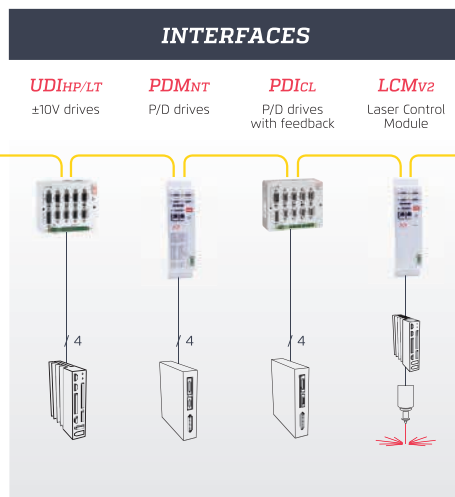
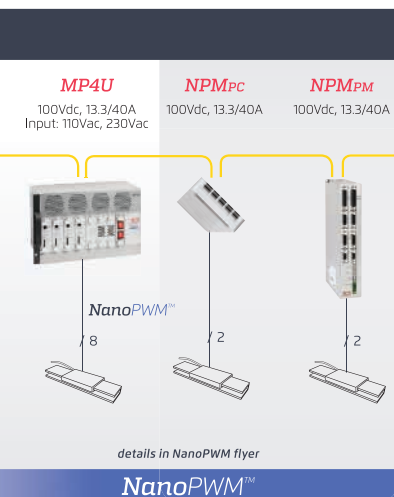

Others

Drives I/Os Sensors

Products supporting CoE protocol

C-885 PIMotionMaster

Rack with Processor and Interface Module for Modular Multi-Axis Controller System



- Easy configuration and start-up: Plug-and-play installation of the controller modules
- Modular design for versatile expansion
- Efficient communication with the controller modules
- Greatly reduced wiring effort
- Saves space and costs
- Optional digital inputs and outputs for every controller module

Available controller modules

- C-863.20C885 2-Channel DC Motor Controller Module
- C-867.10C885 PLine® Controller Module
- E-861.10C885 NEXACT® Controller Module
- E-873.10C885 Q-Motion® Controller Module
- **New:** C-663.10C885 Mercury Step Stepper Motor Controller Module
- **New:** C-891.10C885 PIMag® Controller Module

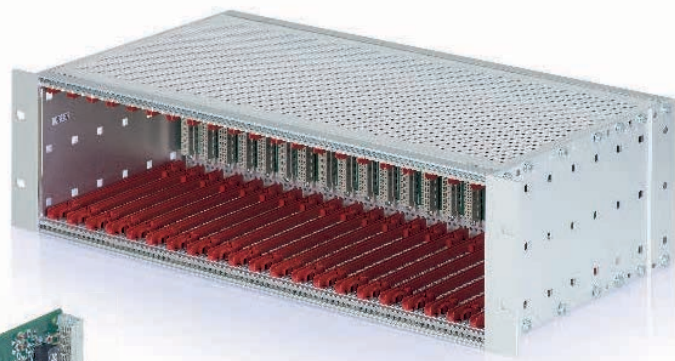

19" rack C-885.R2



Q-Motion® Controller Module with ID chip support for quick start-up

	C-885.R1	C-885.R2
Function	9.5" chassis for C-885 PIMotionMaster modular multi-axis controller system	19" chassis for C-885 PIMotionMaster modular multi-axis controller system
Number of card slots	1 digital processor and interface module (required) 4 controller modules (max.)	1 digital processor and interface module (required) 20 controller modules (max.)
Dimensions	269.04 mm × 133.14 mm × 349.5 mm (including handles)	Without modules: 482.6 mm × 132.55 mm × 265.3 mm With modules: 482.6 mm × 132.55 mm × 278.55 mm
Operating voltage	24 V DC from external power supply	24 V DC from external power supply
Current consumption, max.	32 A	32 A
Mass without modules	3.2 kg	2.9 kg
Operating temperature range	10 to 40 °C	10 to 40 °C

C-885.M1

Function	Digital processor and interface module for C-885 PIMotionMaster modular multi-axis controller system
Interfaces and operation	
Communication interfaces	Ethernet, USB
Command set	PI General Command Set (GCS)
User software	PIMikroMove
Software drivers	LabVIEW drivers, dynamic libraries for Windows and Linux
Advertisements	LEDs for Power, Error
Miscellaneous	
Operating temperature range	10 to 40 °C
Mass	132 g
Dimensions	186.42 mm × 128.4 mm (3 RU) × 19.98 mm (4 HP)

C-884.4DC/C-884.6DC Motion Controllers for DC Motors

4 or 6 Axes, for Positioners with Closed-Loop DC Motor



>> Extensive Software Package

Technology Glossary page 76

- PID servo control with dynamic parameter switching
- Powerful macro programming language, e.g., for stand-alone operation
- Data recorder
- Integrated interfaces: USB, RS-232, Ethernet, SPI, I/O, joystick
- Trajectory support for 1 or 2 D motion patterns

Digital motion controller for DC servo motors

- 4 or 6 axes. Dual core architecture for increased performance and flexibility by separating command processing and PID position control. Simple adaptation / extension for OEM products possible.
- Motion control of PI positioning systems with DC motors: direct motor control, PWM control for PI positioning stages with integrated ActiveDrive amplifiers or for stages with integrated block commutation (brushless motors). Supports motor brake.

Motion profiles

- Point-to-point, trapezoidal velocity profile. User-definable trajectories (e.g., circles, sine curves) from externally fed points.

Extensive functionality

- Powerful macro command language. Nonvolatile macro storage, e.g., for stand-alone functionality with autostart macro. Data recorder. Parameter changing during operation. Extensive software support, e.g., for LabVIEW, shared libraries for Windows and Linux

Interfaces and communication

- Interfaces: TCP/IP, USB and RS-232 for commands. A/B quadrature encoder input. TTL inputs for limit and reference point switches. I/O lines (analog/digital) for automation. USB interface for HID compliant devices.

Scope of Delivery

- Scope of delivery includes wide-range-input power supply with adapter, USB and RS-232 cable, network cable

	C-884.4DC	C-884.6DC
Function	Position control for closed-loop DC motors	
Processor	Dual core architecture. Controller on a DSP core, with extendable command interpreter in an ARM core under Linux	
Axes	4	6
Motion and control		
Servo characteristics	PID controller, parameter changing during operation	
Servo cycle time	100 µs	
Profile generator	Trapezoid velocity profile	
Encoder input	A/B quadrature (TTL differential according to RS-422), 50 MHz; BiSS interface	
Stall detection	Servo off, triggered by programmable position error	
Limit switches	2 × TTL per axis (programmable polarity)	
Reference point switch	1 × TTL per axis	
Motor brake	1 × TTL per axis, can be switched per software	
Electrical properties		
Max. output voltage*	24 V	
Max. output power	240 W	
Current limitation	2.5 A per axis	
Interfaces and operation		
Interface / communication	TCP/IP: RJ45/Ethernet USB: Mini-USB type B RS-232: Sub-D 9 (m) SPI: DisplayPort	
Motor connector	4 × Sub-D 15 (f)	6 × Sub-D 15 (f)
I/O lines	4 analog in (–10 to 10 V) 4 digital in (5 VTTL) 4 digital out (5 VTTL)	
Command set	PI General Command Set (GCS)	
User software	PIMikroMove, PITerminal	
Software drivers	LabVIEW driver, dynamic libraries for Windows and Linux	
Supported functions	Linear vector motion; point-to-point motion; user-definable trajectories; start-up macro; PI Python; data recorder for recording operating data such as motor voltage, velocity, position or position error	
Manual control	USB interface for HID compliant devices	
Miscellaneous		
Operating voltage	External power supply 24 V / 5 A (120 W) included in scope of delivery	
Max. current consumption	11 A	16 A
Current consumption, no load	500 mA	
Operating temperature range	5 to 50 °C	
Mass	1.6 kg	
Dimensions	312 mm × 153.4 mm × 59.2 mm (incl. mounting rails)	

* The output voltage depends on the connected power supply.

C-663.12 Mercury Step Stepper Motor Controller

1 Axis, for Closed-Loop and Open-Loop Operation, HD Sub-D 26, 48 V



>> Extensive Software Package

Technology Glossary page 76

- High microstep resolution
- Operating voltage to 48 V
- Open-loop and closed-loop operation of 2-phase stepper motors
- Support for external sensors
- Daisy chain networking
- Module available for C-885 PIMotionMaster

Mercury Step controller for 2-phase stepper motors

- 1 Axis. Microstep resolution: 1/2048 full step. Open-loop and closed-loop operation. Point-to-point motion, trapezoidal velocity profile. Networkable via daisy chain.

Extensive functionality

- Powerful macro command language. Nonvolatile macro storage, e.g., for stand-alone functionality with autostart macro. Data recorder. ID chip for fast start-up. Parameter changing during operation. Extensive software support, e.g., for LabVIEW, dynamic libraries for Windows and Linux.

Interfaces

- USB and RS-232 for commanding. Differential signal transmission for digital (A/B) encoder signals. TTL inputs for limit and reference point switches. Input for RS-422 signals for index switch. I/O lines (analog/digital) for automation. Interface for analog joystick.
- Scope of delivery incl. 48-V wide-range-input power supply, USB cable, RS-232 cable, network cable for daisy chain and plug adapter for stages with Sub-D 15 connection.

C-663.12

Function	Mercury Step stepper motor controller
Drive types	2-phase stepper motor
Axes	1
Motion and control	
Servo characteristics	PID, parameter changing during operation
Servo cycle time	50 µs
Dynamics profile	Trapezoidal velocity profile, point-to-point motion
Microstep resolution	1/2048 full step
Encoder input	A/B quadrature, TTL, RS-422; 60 MHz
Limit switches	2 × TTL, programmable
Reference point switches	1 × TTL, programmable
Index switch	1 × RS-422 for index pulse
Stall detection	Automatic motor stop when a programmable position error is exceeded (only in conjunction with sensor)
Electrical properties	
Operating voltage	24 to 48 V DC from external power supply (in scope of delivery)
Max. output voltage*	0 V to operating voltage, for direct control of stepper motors
Power consumption, full load	48 W (max.)
Power consumption, no load	3 W
Max. output power (<2 ms)	100 W
Average output power	<48 W
Current limitation per motor phase	2.5 A
Interfaces and operation	
Communication interfaces	USB, RS-232
Motor / sensor connection	HD Sub-D 26 (f)
Controller network	Up to 16 units on a single interface**
I/O lines	4 analog/digital inputs (0 to 5 V /TTL), 4 digital outputs (TTL)
Command set	PI General Command Set (GCS)
User software	PIMikroMove, PITerminal
Software drivers	LabVIEW driver, dynamic libraries for Windows and Linux, MATLAB library
Supported functions	Start-up macro; data recorder for recording operating data such as velocity, position or position error; internal safety circuitry: Watchdog timer; ID chip detection (for future use)
Manual control	Joystick, Y cable for 2-D motion, pushbutton box
Miscellaneous	
Operating temperature range	5 to 50 °C (temperature protection switches off at excessively high temperatures)
Mass	0.48 kg
Dimensions	130 mm × 76 mm × 40 mm (incl. mounting rails)

* Depending on the power supply used

** 16 units with USB; 6 units with RS-232

C-891 PIMag® Motion Controller

For Linear Motors with Average Power Consumption



>> Extensive Software Package

Technology Glossary page 76

- Maximum average current consumption 3 A
- 20 kHz control bandwidth
- USB interface for sending commands and for configuration
- Digital inputs and outputs
- Optional analog input

Digital motion controller for PIMag® linear motors

- 1 motor channel, 1 sensor channel. For three-phase linear motors, maximum current consumption 3A (rms) per phase. Sine-commuted operation, field-oriented current control. Automatic detection of the motor phase. PID controller for position and velocity. 20 kHz servo update rate.

Encoder inputs

- Differential signal transmission for digital (A/B) or analog (sin/cos) encoder signals. BiSS interface support for absolute encoders. TTL signal inputs for limit and reference point switches.

Extensive functionality

- Data recorder: Recording of operating data such as motor current, velocity, position or position error. Wave generator: Saves and outputs periodical motion profiles. ID chip support: Identifies the connected stages and simplifies configuration and exchangeability. Supports direction-sensing reference point switches. Extensive software support, for example for LabVIEW, dynamic libraries for Windows and Linux.

Interfaces

- USB 2.0, RS-232 commanding. Digital inputs and outputs for automation. Analog input for direct control of the motor current.

	C-891.120200	Unit
Function	PIMag® motion controller for 3-phase linear motors, sine-commuted, field-oriented current control	
Motor channels	1	
Sensor channels	1	
Motion and control		
Servo characteristics	PID controller for position and velocity, parameter change on-the-fly	
Servo frequency	20	kHz
Profile generator	Trapezoidal velocity profile, setting of maximum velocity and acceleration	
Encoder input	Analog signals (sin/cos) or digital signals (A/B differential TTL or BiSS interface)	
Reference point switch	TTL	
Electrical properties		
Max. output voltage	24	V
Max. output current	3	A _{rms}
Interfaces and operation		
Communication interfaces	USB, RS-232	
Motor connector	HD Sub-D 26-pin (f)	
Sensor connection	Sub-D 15-pin (m)	
I/O port	4 x digital input 4 x digital output Via HD Sub-D 15-pin (w) Optional analog input, -10 to 10 V	
Command set	PI General Command Set (GCS)	
User software	PIMikroMove	
Software drivers	LabVIEW driver, dynamic libraries for Windows and Linux	
Supported functions	Point-to-point motion, data recorder with 16,000 values and 8 recorder channels, movement, automatic motor phase detection, ID chip detection	
Safety features	Axis stop by hardware switch, overload protection of motor driver, overtemp protection of motor, overcurrent protection of the system	
Miscellaneous		
Operating voltage	24 V, external power supply included in scope of delivery	V
Max. current consumption	4.5	A
Operating temperature range	5 to 40	°C
Max. mass	1.0	kg
Dimensions	190 x 83 x 110 (206 x 83 x 112 including rubber feet and supply voltage connector)	mm

H-855 Modular 6-Axis Hexapod

Modular System for the Highest Adaptability in the 500-kg Class



>> Parallel Kinematics

Technology Glossary page 76

- Modular design, fast and flexible adaptation to requirements
- Horizontal holding force up to 5000 N
- Travel ranges to ± 75 mm, rotation ranges to $\pm 20^\circ$
- Velocities up to 23 mm/s and 200 mrad/s
- Actuator resolution to 5 nm

Modularity

- The H-855 hexapod allows a larger application range to be covered in the 500-kg class. All essential components such as the drive units, position sensors, strut lengths, base and plates as well as joints are modularly designed. The hexapod can be quickly configured to the requirements. Already tested components and efficient production processes simplify realization of customer-specific requirements. Be inspired by 4 of more than 1000 possible configurations.
- Parallel-kinematic design for six degrees of freedom making it significantly more compact and stiff than serial-kinematic systems, higher dynamic range, no moved cables: Higher reliability, reduced friction.

Brushless DC motor (BLDC)

- Brushless DC motors are particularly suitable for high rotational speeds. They can be controlled very accurately and ensure high precision. Because they dispense with sliding contacts, they run smoothly, are wear-free and therefore achieve a long lifetime.

Absolute encoder

- Absolute encoders supply explicit position information that enables immediate determination of the position. This means that referencing is not required during switch-on, which increases efficiency and safety during operation.

Fields of application

- Research and industry. Industrial automation, precision assembly, astronomy, aerospace.

	H-855	H-855	H-855	H-855	Unit	Tolerance
	The golden mean	The fastest	The flattest	With maximum travel range		
Active axes	X, Y, Z, θ_x , θ_y , θ_z	X, Y, Z, θ_x , θ_y , θ_z	X, Y, Z, θ_x , θ_y , θ_z	X, Y, Z, θ_x , θ_y , θ_z		
Motion and positioning						
Travel range in X, Y*	±10	±10	±22.5	±75	mm	
Travel range in Z*	±50	±50	±12.5	±37.5	mm	
Travel range in θ_x , θ_y *	±15	±15	±6.5	±10	°	
Travel range in θ_z *	±35	±35	±10	±20	°	
Actuator design resolution	5	41	5	16	nm	
Max. velocity in X, Y, Z	2.8	25	2.8	9	mm/s	
Max. velocity in θ_x , θ_y , θ_z	25	270	25	70	mrad/s	
Typ. velocity on X, Y, Z	1.5	20	1.5	5	mm/s	
Typ. velocity on θ_x , θ_y , θ_z	14	55	14	39	mrad/s	
Mechanical properties						
Height (motion platform in reference position)	380	380	280	450	mm	
Baseplate diameter	450	450	450	570	mm	
Top plate diameter	300	300	300	360	mm	
Load capacity (base plate horizontal / any orientation)	500 / 200	260 / 120	500 / 200	300 / 200	kg	max.
Holding force, de-energized (base plate horizontal / any orientation)	5000 / 2000	2600 / 1200	5000 / 2000	3000 / 2000	N	max.
Motor type	BLDC gear motor	BLDC gear motor	BLDC gear motor	BLDC gear motor		

* The travel ranges of the individual coordinates (X, Y, Z, θ_x , θ_y , θ_z) are interdependent. The data for each axis in this table shows its maximum travel range, where all other axes and the pivot point are at the reference position.

Technical data specified at 20±3 °C. Ask about custom designs! Specifications for vacuum versions can differ.

H-825 6-Axis Hexapod

Compact Design with Brushless DC Motors (BLDC) and Absolute Encoders for Loads to 30 kg

- Load capacity to 30 kg, self-locking
- Travel ranges to ± 27.5 mm, rotation range to $\pm 11.5^\circ$
- Actuator resolution to 8 nm
- Minimum incremental motion to $0.3 \mu\text{m}$ in X, Y, and Z
- Repeatability to $\pm 0.1 \mu\text{m} / \pm 2 \mu\text{rad}$

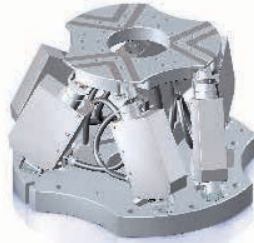

>> Parallel Kinematics

Technology Glossary page 76

	H-825.G2A	H-825.D2A	Unit
Minimum incremental motion in X, Y, Z	0.3	1	μm
Minimum incremental motion in $\theta_x, \theta_y, \theta_z$	3.5	12	μm
Max. velocity in X, Y, Z	2.5	25	mm/s
Load capacity (base plate horizontal / any orientation)	30 / 10	5 / 2.5	kg
Motor type	BLDC gear motor	BLDC motor	
Diameter base plate	300	300	mm
Height	195	195	mm

H-840 6-Axis Hexapod

New Versions with Brushless DC Motors (BLDC) and Absolute Encoders

- High velocity, medium load, affordable
- Load capacity to 30 kg
- Travel ranges to ± 50 mm / $\pm 30^\circ$
- Repeatability to $\pm 0.4 \mu\text{m}$
- MTBF 20,000 h
- Velocity to 80 mm/s
- Works in any orientation



>> Parallel Kinematics

Technology Glossary page 76

	H-840.G2A	H-840.D2A	Unit
Actuator design resolution	0.0085	0.25	μm
Min. incremental motion X, Y	1	3	μm
Min. incremental motion Z	0.5	1	μm
Min. incremental motion $\theta_x, \theta_y, \theta_z$	5	5	μrad
Max. velocity in X, Y, Z	2.5	80	mm/s
Load capacity (base plate horizontal / any orientation)	30 / 10	10 / 3	kg
Motor type	BLDC gear motor	BLDC motor	
Diameter base plate	330	330	mm
Height	320	320	mm

H-850 6-Axis Hexapod

New Versions with Brushless DC Motors (BLDC) and Absolute Encoders for 24/7 Applications

- Load capacity to 250 kg
- Repeatability to $\pm 0.2 \mu\text{m}$
- Travel ranges to $\pm 50 \text{ mm} / \pm 30^\circ$
- Actuator resolution to 2.5 nm
- MTBF 20,000 h
- Works in any orientation



>> Parallel Kinematics

Technology Glossary page 76

	H-850.H2A	H-850.G2A	Unit
Min. incremental motion X,Y	1	1	μm
Min. incremental motion Z	0.5	0.5	μm
Repeatability X,Y	± 1	± 0.5	μm
Repeatability in Z	± 0.3	± 0.2	μm
Diameter base plate	350	350	mm
Height	328	328	mm
Height	195	195	mm

H-811.I2 6-Axis Miniature Hexapod

Fast, Compact, and Highly Precise

- New, robust version for superior lifetime
- Brushless DC motors (BLDC)
- Travel ranges to $\pm 17 \text{ mm} / \pm 21^\circ$
- Load capacity to 5 kg
- Repeatability to $\pm 0.06 \mu\text{m}$
- Velocity to 20 mm/s
- Vacuum-compatible versions available



>> Parallel Kinematics

>> Vacuum-Compatible Versions

Technology Glossary page 76

	H-811.I2	Unit
Actuator design resolution	5	nm
Min. incremental motion X,Y	0.2	μm
Min. incremental motion Z	0.08	μm
Load capacity (base plate horizontal / any orientation)	5 / 2.5	kg
Diameter base plate	135	mm
Height	115	mm

The detailed description including all data is on our homepage at www.pi.ws

H-860 High Dynamics Motion Hexapod

Magnetic Direct Drive for High Velocity

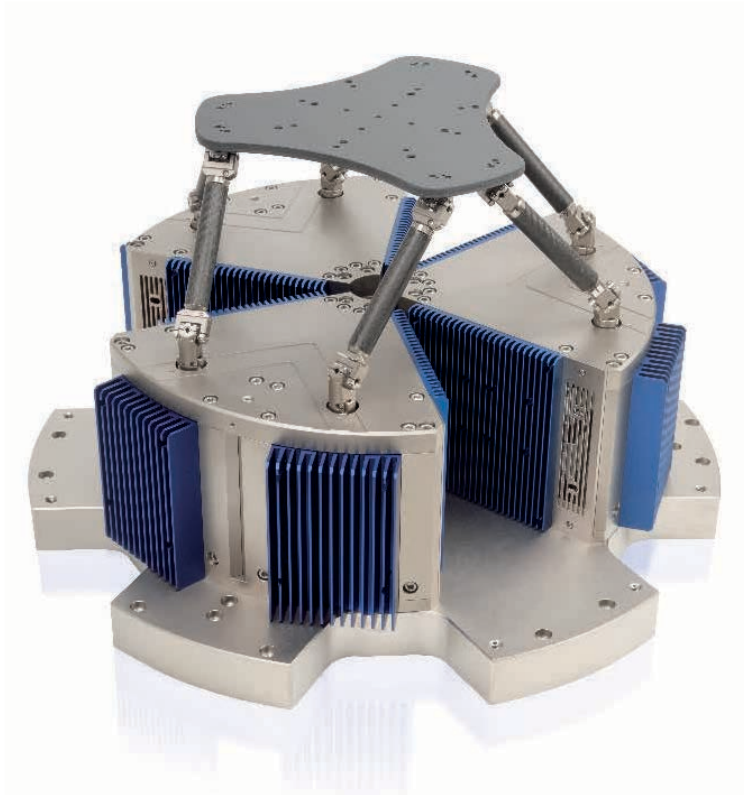

- >> Parallel Kinematics
- >> PIMag® Voice Coil

Technology Glossary page 76

- High velocity and dynamics
- Low moved mass
- Velocity up to 500 mm/s
- Precise path tracking
- Friction-free voice coil drive

Fields of application

- Research and industry, test systems, e.g., for image stabilization in cameras and mobile devices. Equipment for camera test systems and image stabilization software. Oscillation simulation, eye tracking, simulation of human and artificial motion.

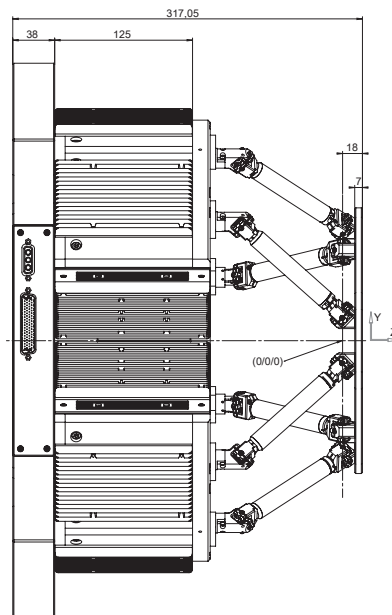
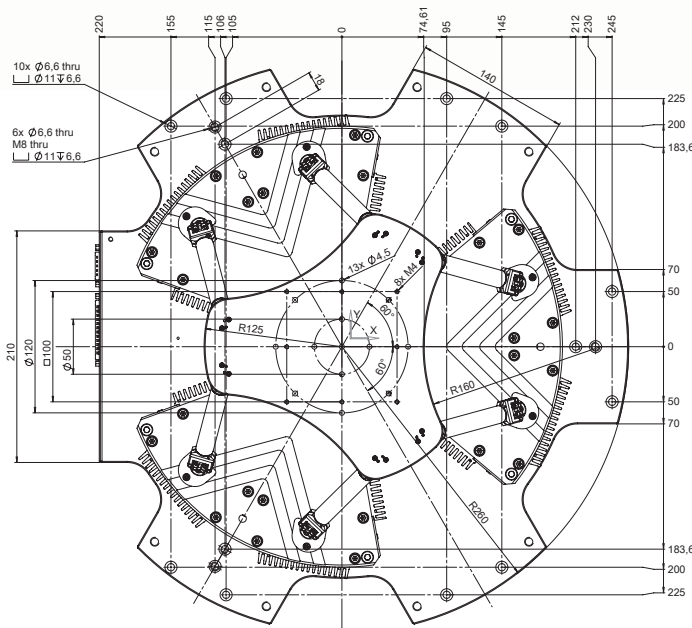

Preliminary data	H-860.S2H	Unit	Tolerance
Active axes	X, Y, Z, θ_x , θ_y , θ_z		
Motion and positioning			
Travel range* in X, Y, Z	±7.5	mm	
Travel range* in θ_x , θ_y , θ_z	±4	°	
Actuator design resolution	5	nm	
Minimum incremental motion in X, Y	1	μm	typ.
Minimum incremental motion in Z	1	μm	typ.
Minimum incremental motion in θ_x , θ_y , θ_z	9	μrad	typ.
Backlash in X, Y	0.2	μm	typ.
Backlash in Z	0.06	μm	typ.
Backlash in θ_x , θ_y	4	μrad	typ.
Backlash in θ_z	4	μrad	typ.
Unidirectional repeatability in X, Y	±0.5	μm	typ.
Unidirectional repeatability in Z	±0.5	μm	typ.
Unidirectional repeatability in θ_x , θ_y	±9	μrad	typ.
Unidirectional repeatability in θ_z	±9	μrad	typ.
Velocity in X, Y, Z	250	mm/s	max.
Frequency bandwidth, 100 % step in X, Y, Z	2.8	Hz	
Amplitude-frequency product in X, Y, Z	30	mm/s	
Amplitude-frequency product in θ_x , θ_y , θ_z	15	°/s	
Amplitude error	10	%	max.
Phase error	60	°	max.
Mechanical properties			
Stiffness in X, Y	0.7	N/μm	
Stiffness in Z	8	N/μm	
Load capacity (base plate horizontal / any orientation)	1	kg	max.
Motor type	Voice coil		
Miscellaneous			
Operating temperature range	0 to 50	°C	
Material	Stainless steel, aluminum		
Mass	30	kg	±5 %

* The travel ranges of the individual coordinates (X, Y, Z, θ_x , θ_y , θ_z) are interdependent. The data for each axis in this table shows its maximum travel range, where all other axes and the pivot point are at the reference position.

Technical data specified at 20±3 °C.
Ask about custom designs!

C-887.52x Hexapod Motion Controller

Compact Bench-Top Device for Controlling 6-Axis Systems



>> Extensive Software Package

Technology Glossary page 76

- Sophisticated controller using vector algorithms
- Commanding in Cartesian coordinates
- Changes of the reference system with a simple command
- Analog interfaces and Motion Stop

Digital controller for 6-axis parallel kinematics

- High-performance digital controller for hexapods with DC motors. Additional control for two further single axes with integrated ActiveDrive.

Functions

- Position input via Cartesian coordinates, coordinate transformation handled by the controller. Easy change of the reference system (Work, Tool). The real-time operating system prevents jitter and therefore guarantees constantly low response times. Stable, virtual pivot point can be freely defined in space. Data recorder for operating parameters such as motor control, velocity, position or position errors. Macro command language. The controller supports motor brakes and absolute-measuring sensors with BiSS interface.

Interfaces

- Ethernet for remote control and remote maintenance. RS-232. USB connection for external input devices (HID).
- Additional interfaces (depending on version):
 - Motion Stop: No reference move is not necessary when the drive is reactivated
 - Analog inputs

Optional

- Control via manual control unit
- Collision checking for restricted space with PIVeriMove software

EtherCAT[®]

Also available: C-887.53x Hexapod Motion Controller with EtherCAT[®] fieldbus interface

- Can be integrated seamlessly into automation systems in industry and research. Performs coordinate transformation for parallel kinematics. Cycle time 1 ms
- Customer requires a higher-level PLC control for position commanding and feedback in Cartesian coordinates (EtherCAT master with CoE protocol).

EtherCAT[®] is a registered trade mark and patented technology of Beckhoff Automation GmbH, Germany

C-887.52, C-887.521, C-887.522, C-887.523

Function	6-axis controller for hexapods, incl. control of two additional single axes Compact benchtop Extending the functionality of C-887.52: C-887.521: Additional Analog Inputs C-887.522: Additional Motion Stop C-887.523: Additional Motion Stop and Analog Inputs
Drive type	Servo motors (hexapod and single axes)
Motion and control	
Servo characteristics	32-bit PID controller
Trajectory profile modes	Jerk-controlled generation of dynamics profile with linear interpolation
Processor	Intel Atom dual core (1.8 GHz)
Servo cycle time	100 µs
Encoder input	AB (quadrature) differential TTL signal, 50 MHz BiSS
Stall detection	Servo off, triggered by position error
Reference point switch	TTL
Electrical properties	
Hexapod control	12-bit PWM signal, TTL, 24 kHz
Hexapod power source	24 V
Maximum output current	7 A
Interfaces and operation	
Interface / communication	TCP/IP, RS-232 USB (HID, manual control unit)
Hexapod connection	HD Sub-D 78-pin (f) for data transfer M12 4-pin (f) for power supply
Connectors for single axes	Sub-D 15-pin (f)
I/O lines	HD Sub-D 26-pin (f): 4 × analog input (-10 to 10 V, via 12-bit A/D converter) 4 × digital input (TTL) 4 × digital output (TTL) 2 × BNC, -5 V to 5 V, via 16-bit A/D converter, 5 kHz bandwidth
Analog inputs, only C-887.521 and C-887.523	2 × BNC, -5 V to 5 V, via 16-bit A/D converter, 5 kHz bandwidth
Input for Motion Stop, only C-887.522 and C-887.523	M12 8-pin (f)
Command set	PI General Command Set (GCS)
User software	PIMikroMove
Software drivers	LabVIEW driver, dynamic libraries for Windows and Linux
Manual operation	Optional: C-887.MC manual control unit for hexapods
Miscellaneous	
Operating voltage	24 V external power supply for 100 to 240 VAC, 50 / 60 Hz, in the scope of delivery
Maximum current consumption	8 A
Operating temperature range	5 to 40 °C
Mass	2.8 kg
Dimensions	280 (320) mm × 150 mm × 103 mm Power supply: 170 mm × 85 mm × 42.5 mm

Scope of Delivery

The order is made together with suitable hexapod mechanics. Delivery comprises the Hexapod Motion Controller, a hexapod, a cable set, and a power supply as power source.

Q-821 Q-Motion® Miniature SpaceFAB Robot

Piezo-Motorized Inertia Drive, only 80 mm Side Length

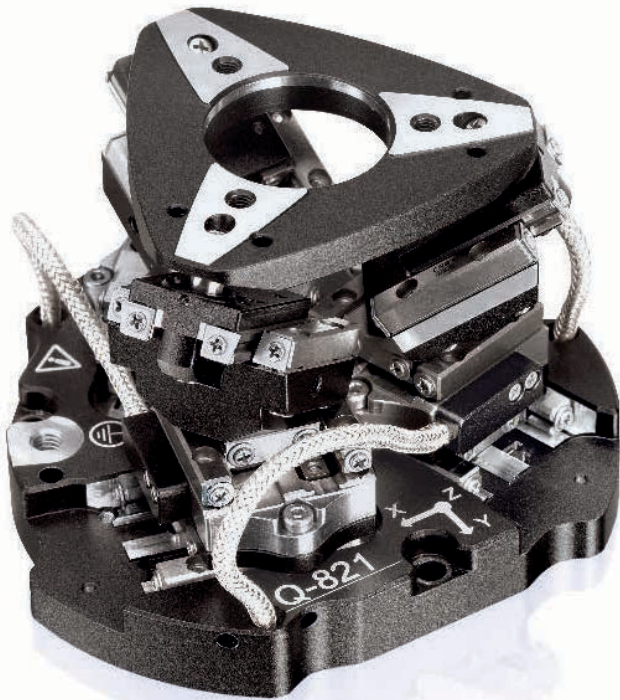

- >> Parallel Kinematics
- >> Q-Motion® Piezoelectric Inertia Drive

Technology Glossary page 76

- Six-axis microrobotics system
- Linear travel ranges to 6 mm × 6 mm × 3 mm
- Rotary travel ranges to 6° × 6° × 16.5°
- 1 nm sensor resolution

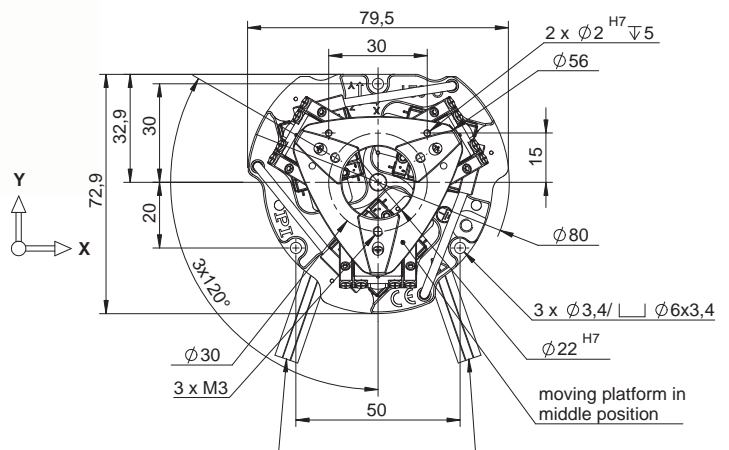
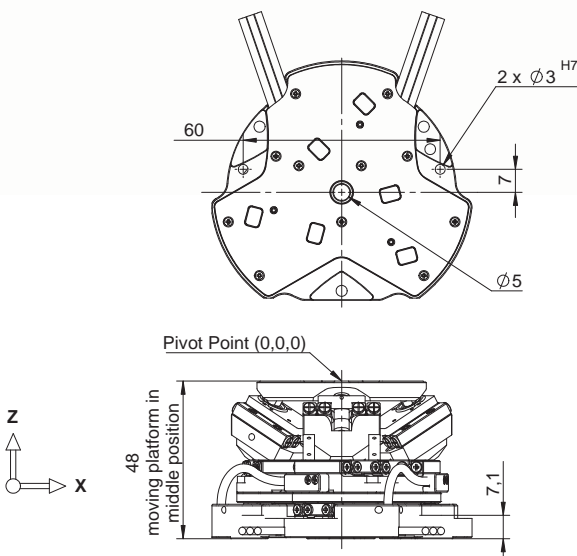

Q-821.140, dimensions in mm

Piezoelectric inertia drive

- Piezo inertia drives are space-saving and affordable piezo-based drives with relatively high holding forces and a virtually unlimited travel range. The inertia drive principle is based on a single piezoelectric actuator that is controlled with a modified sawtooth voltage provided by special drive electronics. The actuator expands slowly and moves the runner. Due to its inertia, the runner is unable to follow the subsequent fast contraction of the actuator and remains at its position. The operating frequency of up to 20 kHz enables directly driven runners to achieve velocities of more than 5 mm/s.

Crossed roller bearings

- With crossed roller bearings, the point contact of the balls in ball bearings is replaced by a line contact of the hardened rollers. Consequently, they are considerably stiffer and need less preload, which reduces friction and allows smoother running. Crossed roller bearings are also distinguished by high guiding accuracy and load capacity. Force-guided rolling element cages prevent linear guide creeping.

Fields of application

- Industry and research. Measuring technology, microscopy, micromanipulation, biotechnology, and automation.

Preliminary data	Q-821,140	Unit	Tolerance
Motion and positioning			
Active axes	X, Y, Z, +X, θ_x , θ_z		
Integrated sensor	Incremental linear encoder		
Travel range in X, Y	±6	mm	
Travel range in Z	±3	mm	
Rotation range in θ_x , θ_y	±6	°	
Rotation range in θ_z	±16.5	°	
Sensor resolution	1	nm	
Mechanical properties			
Load capacity in X, Y	1	N	max.
Load capacity in Z (base plate horizontal)	2	N	max.
Drive type	Piezoelectric inertia drive		
Miscellaneous			
Connection	6x Sub-D 15 (m)		
Material	Stainless steel, aluminum		
Mass without cable and connector	0.3	kg	±5 %
Cable length	2	m	±10 mm

Q-845 Q-Motion® SpaceFAB

High Precision and High Stiffness

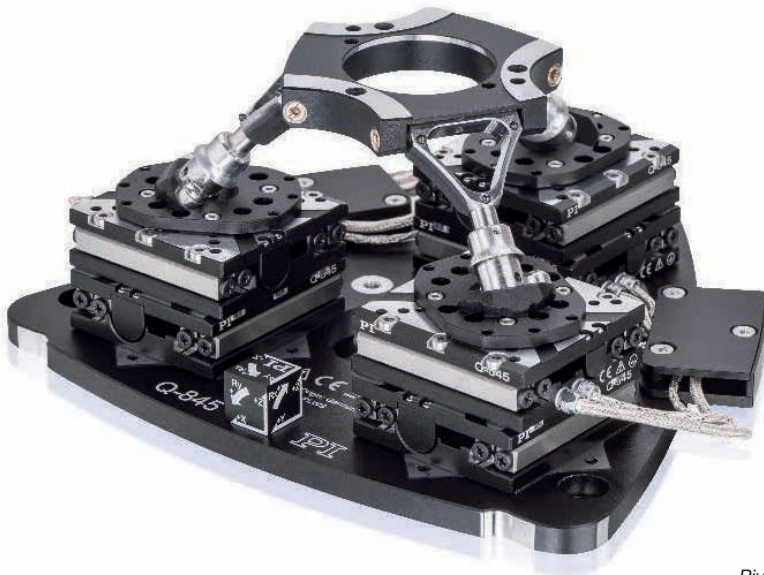

- >> Parallel Kinematics
- >> Q-Motion® Piezoelectric Inertia Drive
- >> Vacuum-Compatible Versions

Technology Glossary page 76

- Six degrees of freedom
- ± 7 mm travel range in X and Y, and ± 5 mm in Z
- $\pm 7^\circ$ rotation range in θ_x , θ_y , and $\pm 8^\circ$ in θ_z
- 10 N load capacity, center mounted
- Self-locking, no heat generation at rest
- Vacuum-compatible to 10^{-6} hPa

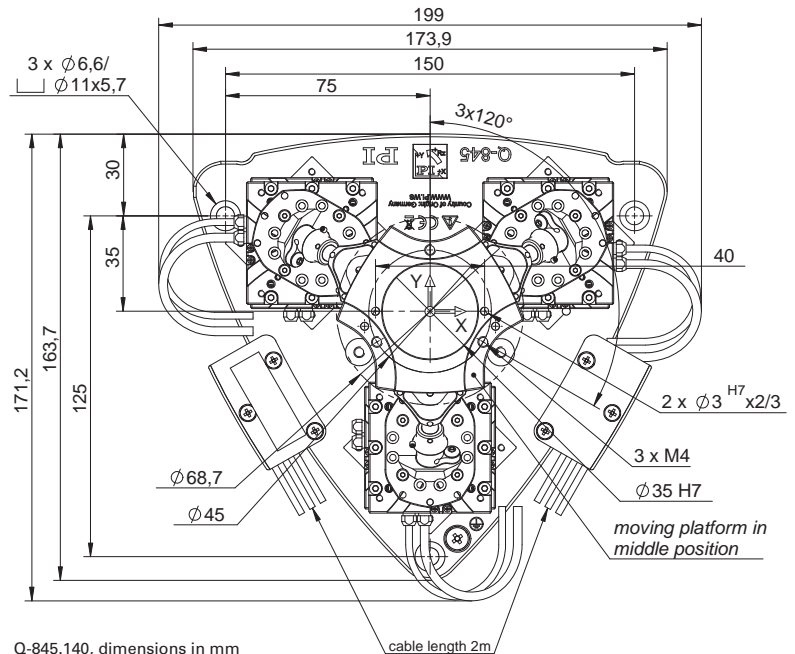
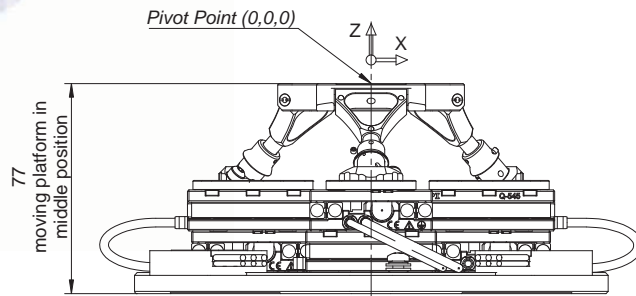

Q-845.140, dimensions in mm

Preliminary data	Q-845.140	Unit	Tolerance
Motion and positioning			
Active axes	X, Y, Z, θ_x , θ_y , θ_z		
Integrated sensor	Incremental linear encoder		
Travel range in X, Y	± 7	mm	
Travel range in Z	± 5	mm	
Rotation range in θ_x , θ_y	± 7	°	
Rotation range in θ_z	± 8	°	
Sensor resolution	1	nm	
Minimum incremental motion in X, Y	6	nm	typ.
Minimum incremental motion in Z	20	nm	typ.
Minimum incremental motion in θ_x , θ_y , θ_z	0.9	μ rad	typ.
Unidirectional repeatability in X, Y	± 30	nm	typ.
Unidirectional repeatability in Z	± 35	nm	typ.
Unidirectional repeatability in θ_x	± 20	μ rad	typ.
Unidirectional repeatability in θ_y	± 10	μ rad	typ.
Unidirectional repeatability in θ_z	± 6	μ rad	typ.
Backlash in X, Y	40	nm	typ.
Backlash in Z	60	nm	typ.
Backlash in θ_x , θ_y	35	μ rad	typ.
Backlash in θ_z	20	μ rad	typ.
Max. velocity in X, Y, Z	5	mm/s	max.
Max. angular velocity in θ_x , θ_y , θ_z	50	mrad/s	max.
Mechanical properties			
Load capacity in X, Y	5	N	max.
Load capacity in Z (base plate horizontal)	10	N	max.
Permissible torque in θ_x , θ_y , θ_z	0.5	N·m	max.
Drive type	Piezoelectric inertia drive		
Miscellaneous			
Connection	6x Sub-D 15 (m)		
Material	Stainless steel, aluminum		
Mass	1.9	kg	± 5 %
Mass without cable and connector	1.2	kg	± 5 %
Cable length	2	m	± 10 mm

The travel ranges of the individual coordinates (X, Y, Z, θ_x , θ_y , θ_z) are interdependent. The data for each axis in this table shows its maximum travel range, where all other axes and the pivot point are at the reference position.

The detailed description including all data is on our homepage at www.pi.ws

	N-865.160	Unit	Tolerance
Motion and positioning			
Active axes	X, Y, Z, θ_x , θ_y , θ_z		
Integrated sensor	Incremental linear encoder PIOne		
Travel range* in X, Y	±6.5	mm	
Travel range* in Z	±5	mm	
Rotation range* in θ_x , θ_y	±7	°	
Rotation range* in θ_z	±8	°	
Sensor resolution	0.5	nm	
Minimum incremental motion in X, Y	2	nm	typ.
Minimum incremental motion in Z	2	nm	typ.
Minimum incremental motion in θ_x , θ_y , θ_z	0.2	μrad	typ.
Unidirectional repeatability in X	±40	nm	typ.
Unidirectional repeatability in Y	±30	nm	typ.
Unidirectional repeatability in Z	±20	nm	typ.
Unidirectional repeatability in θ_x	±5	μrad	typ.
Unidirectional repeatability in θ_y	±7	μrad	typ.
Unidirectional repeatability in θ_z	±7	μrad	typ.
Backlash in X	70	nm	typ.
Backlash in Y	30	nm	typ.
Backlash in Z	20	nm	typ.
Backlash in θ_x	12	μrad	typ.
Backlash in θ_y	9	μrad	typ.
Backlash in θ_z	4	μrad	typ.
Max. velocity in X, Y, Z		mm/s	max.
Max. angular velocity in θ_x , θ_y , θ_z		mrads	max.
Mechanical properties			
Stiffness in X, Y		N/μm	
Stiffness in Z		N/μm	
Load capacity in X, Y	7,5	N	max.
Load capacity in Z (base plate horizontal)	15	N	max.
Drive type	NEXACT® piezo walking drive		
Miscellaneous			
Connection	HD Sub-D 78 (m)		
Sensor connection	2x HD Sub-D 26 (f)		
Material	Stainless steel, aluminum		
Mass	3.9	kg	±5 %
Operating temperature range	10 to 50	°C	

* The travel ranges of the individual coordinates (X, Y, Z, θ_x , θ_y , θ_z) are interdependent. The data for each axis in this table shows its maximum travel range, where all other axes and the pivot point are at the reference position.

Technical data specified at 20±3 °C.
Ask about custom designs!

E-873.3QTU Q-Motion® Servo Controller

3 axes, for positioners with piezo inertia drives



- >> Extensive Software Package
- >> Q-Motion® Piezoelectric Inertia Drive

Technology Glossary page 76

- Broadband encoder input
- Macro programmable for stand-alone functionality
- Data recorder
- Nonvolatile EEPROM for macros and parameters
- Digital I/O ports (TTL)
- ID chip support
- Interfaces: TCP/IP and USB
- Benchtop device
- Optional digital joystick for manual operation

E-873.3QTU

Channels	3
Max. output power	30 W per axis
Max. current consumption	5 A
I/O lines	4 digital inputs, 4 digital outputs
Software drivers	LabVIEW drivers, shared libraries for Windows and Linux
Supported functions	Point-to-point motion, start-up macro, data recorder for recording parameters such as motor voltage, position or position error; internal safety circuitry: Watchdog timer; ID chip
Operating voltage	24 V (external power supply with 24 V / 5 A in scope of delivery)
Dimensions	300 mm × 60 mm × 160 mm

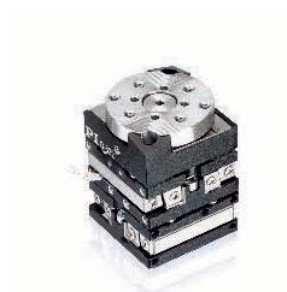

Multi-axis combination of Q-Motion® stages: 2 × Q-522 linear stage and Q-622 rotary stage

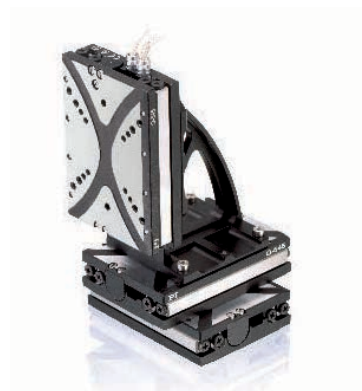

XYZ-setup of 3 × Q-545 linear stages

E-872.401 Q-Motion® Piezomotor/ PiezoMike Drive Electronics

4 Channels, Demultiplexing, Benchtop Device



- >> Extensive Software Package
- >> Q-Motion® Piezoelectric Inertia Drive

Technology Glossary page 76

- For positioners with Q-Motion® piezo inertia drives and PiezoMike linear actuators
- Inexpensive multi-channel concept:
Demultiplexing for up to 64 channels as 19" housing variant possible
- Integrated interfaces: TCP/IP, USB, USB for Joystick, Digital I/O



XYZ setup of Q-521 stages

Preliminary data E-872.401

Function	Driver electronics for Q-Motion® positioners and PiezoMike linear actuators; benchtop device
Output voltage	0 to 100 V
Communication interfaces	USB, Ethernet
Actuator connection	4 x LEMO connector, 3-pin
Analog and digital inputs	Analog ±10 V, 10-bit ADC, TTL inputs for commanding and configuring
Dimensions	137 mm x 105.5 mm x 43.82 mm
Mass	0.44 kg

The detailed description including all data is on our homepage at www.pi.ws

U-780 PILine® XY Stage System with Controller and Joystick

Stable, dynamic, low profile; for inverted microscopes



- >> Extensive Software Package
- >> PILine® Ultrasonic Piezomotors

Technology Glossary page 76

- High velocity constancy at 10 $\mu\text{m/s}$
- Velocity to 120 mm/s, resolution 0.1 μm
- Travel range 135 mm \times 85 mm (Nikon, Leica) or 100 mm \times 75 mm (Olympus)
- For inverted microscopes, freely revolving nosepiece
- Compact, flat design: Unrestricted access to the sample
- Extensive accessories: Z sample scanners, microscope slide holder and Petri dish and microtiter plate holder
- Includes C-867.2U2 controller and joystick
- Compatible with $\mu\text{Manager}$, MetaMorph, Andor iQ, MATLAB

Suitable for the following inverted microscopes:

- Nikon Eclipse Ti-E/Ti-U/Ti-S
- Olympus IX2
- Leica DMI

User software

PIMikroMove. PI General Command Set (GCS). Drivers for LabVIEW. Compatible with $\mu\text{Manager}$, MetaMorph, Andor iQ, MATLAB.

Large range of accessories

M-687.AP1 universal holder for microscope slides and Petri dishes

P-736 Plnano® Z microscope scanner for microtiter plates

P-545.xR8S Plnano® XY(Z) piezo system

P-737 PIFOC® specimen-focusing Z stage

	U-780.DNS	U-780.DOS	U-780.DLS	Unit	Tolerance
	System with M 687.UN for Nikon microscopes	System with M 687.UO for Olympus microscopes	System with M 687.UL for Leica microscopes		
Active axes	X,Y	X,Y	X,Y		
Motion and positioning					
Travel range	135 mm × 85 mm	100 mm × 75 mm	135 mm × 85 mm		
Integrated sensor	Linear encoder	Linear encoder	Linear encoder		
Sensor resolution	0.1	0.1	0.1	µm	
Bidirectional repeatability	±0.3	±0.3	±0.3	µm	
Pitch / yaw	±300	±300	±300	µrad	typ.
Velocity	120	120	120	mm/s	max.
Reference point switches	Optical, 1 µm repeatability	Optical, 1 µm repeatability	Optical, 1 µm repeatability		
Limit switches	Hall effect	Hall effect	Hall effect		
Mechanical properties					
Load capacity	25	25	25	N	max.
Drive properties					
Motor type	PILine® ultrasonic piezomotor, performance class 2	PILine® ultrasonic piezomotor, performance class 2	PILine® ultrasonic piezomotor, performance class 2	N	max.
Miscellaneous					
Operating temperature range	20 to 40	20 to 40	20 to 40	°C	
Material	Al (black anodized)	Al (black anodized)	Al (black anodized)		
Mass of the stage	4.2	3.2	4.2	kg	±5 %
Piezomotor controller	C-8672U2 with USB joystick (included in scope of delivery)				
Interface / communication	USB, RS-232, SPI, Ethernet				
I/O lines	4 analog/digital inputs 4 digital outputs to mini DIN, 9-pin Digital: TTL Analog: 0 to 5 V				
Command set	PI General Command Set (GCS)				
User software	PIMikroMove				
Software drivers	GCS DLL (with code examples for the most common programming languages such as C++, C#, VB.NET, Python, Delphi), LabVIEW driver, MATLAB library				
Supported functions	Start-up macro, macro, data recorder for recording operating data such as motor voltage, velocity, position or position error				
Controller dimensions	312 mm × 153.4 mm × 59.3 mm (incl. mounting rails)				

N-331 PICMAWalk Walking Drive

OEM Walking Drive for Durable Applications with up to 15 mm/s Velocity and up to 50 N Push/Pull Force



- >> Flexure Guiding Systems
- >> PICMA® Multilayer Piezo Actuators
- >> PiezoWalk® Walking Drive

Technology Glossary page 76

- Robust walking drive with PICMA® technology and extreme durability for industrial use
- Fastest and strongest drive of its size class
- Variable runner lengths from 25 mm to 100 mm
- Precise, nanometer precision positioning of loads up to 5 kg
- Plug-and-play, thanks to PI proprietary controller technology

E-712.1AN, E-712.2AN, E-712.3AN Digital Controller for PICMAWalk Walking Drives

1 to 3 Channels for Drives with Incremental Sensors



- >> Extensive Software Package

Technology Glossary page 76

- Customized control algorithms for PICMAWalk walking drives
- For one to three channels
- Plug-and-play, thanks to PI proprietary controller technology
- Flexible interfaces: TCP/IP, USB, RS-232, SPI
- Compatible with GCS (PI General Command Set)

	N-331.10 / N-331.13 N-331.20 / N-331.23 N-331.40 / N-331.43	Unit	Tolerance
Active axes	X		
Motion and positioning			
Integrated sensor	N-331.x0: Without sensor N-331.x3: With incremental sensor		
Travel range (step mode, open loop)*	N-331.1x: 30 N-331.2x: 55 N-331.4x: 105	mm	±0.5 mm
Travel range (step mode, closed loop)	N-331.1x: 25 N-331.2x: 50 N-331.4x: 100	mm	
Step size	10 nm to 25 µm		typ.
Step frequency**	600	Hz	max.
Velocity (step mode)**	15	mm/s	max.
Travel range (analog mode)	±10	µm	typ.
Resolution (open loop)	0.02	nm	typ.
Resolution (closed loop)	<10 (N-331.x3)	nm	typ.
Endurance (atmospherical operation)***	>30	km	
Mechanical properties			
Stiffness in motion direction	6	N/µm	±20 %
Push/pull force (active)	50	N	max.
Holding force (passive)	60	N	max.
Drive properties			
Drive type	PICMAWalk		
Operating voltage	-20 to 120	V	
Connectors			
Connector	Sub-D 37-pin (m)		
Miscellaneous			
Operating temperature range	-20 to 50	°C	
Material	Aluminum, stainless steel		
Mass with cable	610	g	
Moved Mass	N-331.1x: 110 N-331.2x: 140 N-331.4x: 190	g	±10 g
Cable length	2.0	m	±10 mm
Recommended controllers / amplifiers	E-712.1AN, E-712.2AN, E-712.3AN		
Dimensions	Drive dimensions without runner: 55 mm × 55 mm × 31 mm Runner length: N-331.1x: L = 99 mm, N-331.2x: L = 124 mm, N-331.4x: L = 174 mm		

* From one mechanical hard stop of the runner to the other mechanical hard stop, only in open-loop operation

** When operating with the E-712.xAN

*** At a load of 2 kg with max. 70 % duty cycle and external cooling of the E-712.1AN, at 20 °C and 1013 hPa

P-616 NanoCube® Nanopositioner

Compact Parallel-Kinematic Piezo System for Nanopositioning and Fiber Alignment



- >> Capacitive Sensors
- >> Flexure Guiding Systems
- >> PICMA® Multilayer Piezo Actuators

Technology Glossary page 76

- Parallel-kinematic design for the highest stiffness in all spatial directions
- Highly dynamic motion due to high resonant frequencies even with loads up to 100 g
- Innovative product design for flexible use due to single mounting platform
- Only nanopositioner available on the market with ID chip functionality for plug-and-play with digital piezo controllers
- Smallest and lightest NanoCube® with 100 µm travel range on the market

P-616, dimensions in mm.
Note that the decimal places are separated by a comma in the drawings.

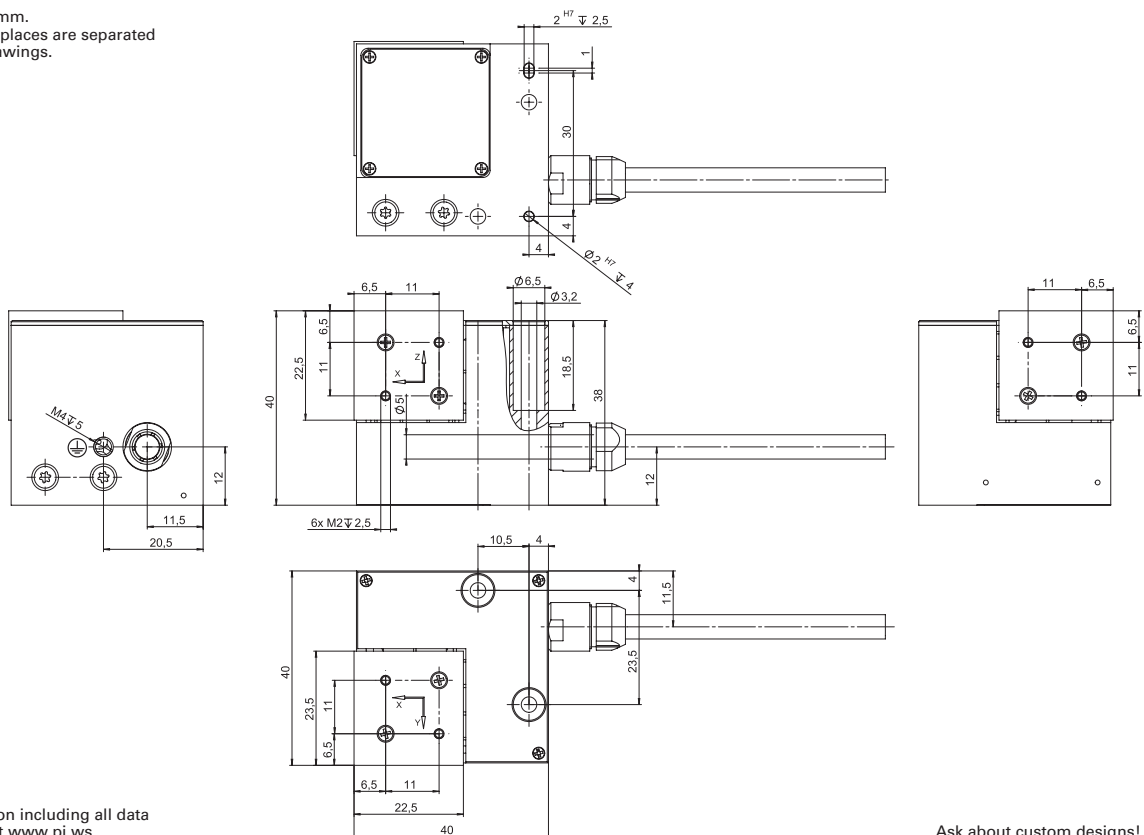

Preliminary data	P-616.3C	Unit	Tolerance
Motion and positioning			
Active axes	X, Y, Z		
Open-loop travel, -20 to 120 V	110 / axis	μm	+20 % / -0 %
Closed-loop travel range	100 / axis	μm	+20 % / -0 %
Min. incremental motion, 1 σ, open-loop*	0.3	nm	typ.
Min. incremental motion, 1 σ, closed-loop*	0.4	nm	typ.
Linearity error, for the entire travel range, with digital controller (E-727.3CD)	0.03	%	typ.
Bidirectional repeatability, 1 σ, 10 % of travel range	<10	nm	typ.
Bidirectional repeatability, 1 σ, 100 % of travel range	<15	nm	typ.
Sensor			
Sensor type	Capacitive sensors		
Mechanical properties			
Stiffness	0.5	N/μm	±10 %
Unloaded resonant frequency X / Y / Z	700	Hz	±10 %
Resonant frequency with 38 g load X / Y / Z	380	Hz	±20 %
Resonant frequency with 100 g load X / Y / Z	250	Hz	±20 %
Push force capacity **, ***	15	N	max.
Holding force, passive **, ***	15	N	max.
Maximum permissible torque ***	0.4	nm	max.
Load capacity ****	300	g	max.
Drive properties			
Ceramic type	PICMA® P-885.50		
Electrical capacitance	1.5 / axis	μF	±20 %
Miscellaneous			
Operating temperature range *****	-20 to 80	°C	
Material	Aluminum, steel		
Dimensions	40 × 40 × 40	mm	
Moved mass without load	0.021	kg	
Mass without cable	0.125	kg	
Mass with cable	0.4	kg	
Cable length	1.5	m	±10 mm
Connection	Sub-D 25W3 (m)		

* Resolution of PI piezo nanopositioning systems is not limited by friction or stiction
 ** In motion direction as well as against motion direction of all axes, at any orientation of the stage
 *** Maximum permissible for XYZ mounting platform, at any orientation of the stage
 **** At maximum load, the operating frequency that can be reached is approx. 50 Hz
 ***** The specifications apply to 21 °C ±10 °C, specifications may deviate outside of this range. Contact our customer service department (service@pi.de).

Recommended controllers / amplifiers

Digital controllers: E-727-3CD / E-727.3CDA digital multi-channel piezo controllers for capacitive sensors.
 Analog controllers / amplifiers: E-500 modular piezo controller system with E-503.00 amplifier module (three channels) and E-509.C3A piezo servo module or E-663 piezo amplifier (three channels).
 The P 895.3DLC adapter cable is necessary for the analog controller / amplifier.

S-335 Fast Tip/Tilt Platform

Short Settling Time and High Dynamic Linearity



>> Flexure Guiding Systems
>> PICMA® Multilayer Piezo Actuators

Technology Glossary page 76

- Tip/tilt angle to 35 mrad, high optical deflection angle to 70 mrad (4°)
- High resonant frequencies for dynamic motion and fast step-and-settle
- ID chip support for fast start-up
- Strain sensors for high linearity
- Parallel-kinematic design: Two orthogonal tip/tilt axes with one common center of rotation
- For mirrors to Ø 25.4 mm (1") (can be supplied with mirror on request)
- Recommended controller E-727

S-335.2SH: Dimensions in mm.
Note that the decimal places are separated by a comma in the drawings.

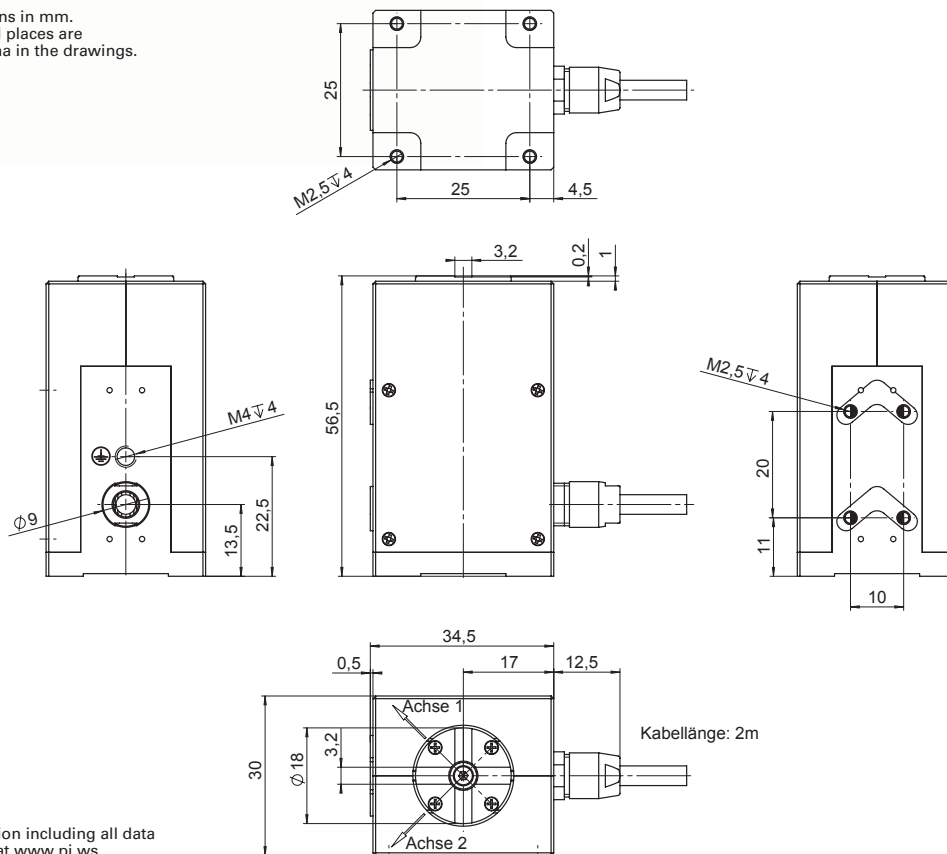

Preliminary data	S-335.2SH	Unit	Tolerance
Active axes	θ_x, θ_y		
Motion and positioning			
Integrated sensor	SGS		
Tip/tilt angle, closed loop (static motion at 0 to 120 V)	± 17.5	mrad	
Open-loop resolution	0.1	μrad	typ.
Closed-loop resolution	0.2	μrad	typ.
Linearity	0.05 (unidirectional)	%	typ.
Repeatability	1 (bidirectional)	μrad	typ.
Mechanical properties			
Resonant frequency, no load	2.0	kHz	± 20 %
Resonant frequency, under load (with $\varnothing 12.7 \times 3$ mm Zerodur mirror)	1.7	kHz	± 20 %
Resonant frequency, under load (with $\varnothing 25.4 \times 5$ mm Zerodur mirror)	0.7	kHz	± 20 %
Gap between the center of rotation and platform surface	3.3	mm	± 0.5 mm
Drive properties			
Ceramic type	PICMA® P-885		
Electrical capacitance per axis	6.2	μF	± 20 %
Miscellaneous			
ID chip functionality	Yes		
Operating temperature range	0 to 50	°C	
Material platform	Titanium		
Mass (with cable and connector)	280	g	± 5 %
Cable length	2	m	+0.1 m
Sensor / voltage connection	Sub-D 37 connector (m)		

P-545.xC8S PInano® Cap XY(Z) Piezo System

Capacitive Positioning Measurement for Superresolution Microscopy



- >> Capacitive Sensors
- >> Extensive Software Packages
- >> Flexure Guiding Systems
- >> PICMA® Multilayer Piezo Actuators

Technology Glossary page 76

- Highest stability and repeatability
- Travel ranges to 200 µm × 200 µm × 200 µm
- Aperture for standard microscope slides (25 mm × 75 mm)
- Subnanometer resolution
- Fast response in the ms range
- Low profile for easy integration: 20 mm
- Recessed sample holders, freely revolving nosepiece
- Fits to M-545 microscope stage
- Includes E-727 USB controller

For more PInano® XY(Z) Microscopy visit www.pi.ws:

- Higher dynamics: P-545.3D8S
- Cost-effective alternative: P-545.xR8S

P-545.xx8S, dimensions in mm

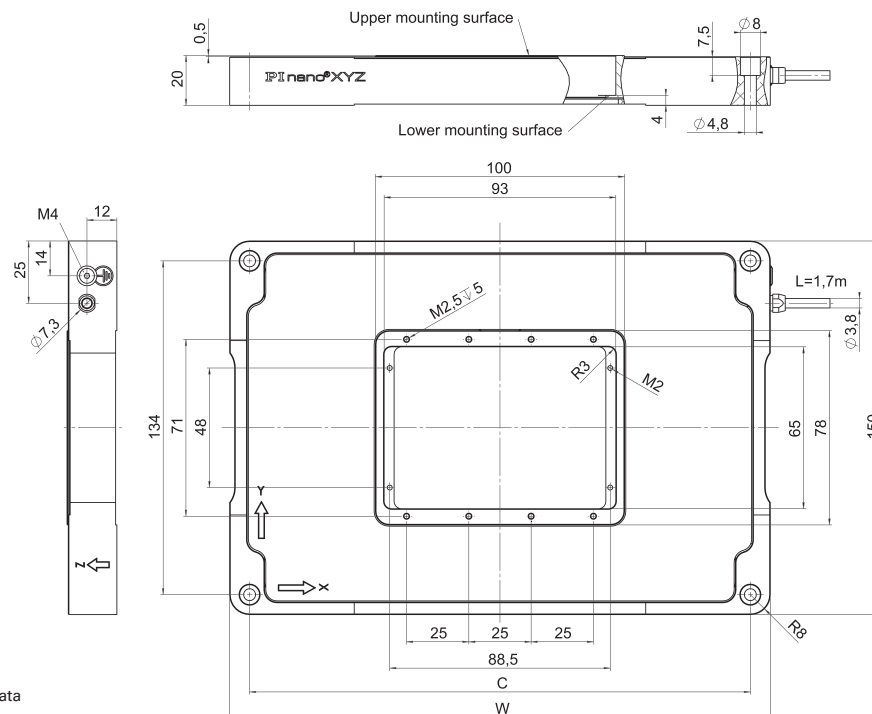

Model	W	C
P-545.3x8S	217	201
P-545.2x8S	182	166

	P-545.2C8S	P-545.3C8S	Unit	Tolerance
Active axes	X, Y	X, Y, Z		
Motion and positioning				
Integrated sensor	Capacitive	Capacitive		
Closed-loop travel range	200 × 200	200 × 200 × 200	μm	
Closed-loop resolution*	<1	<1	nm	typ.
Mechanical properties				
Compressive / tensile stress capacity	50 / 30	50 / 30	N	max.
Recommended load**	0.5	0.5	kg	max.
Drive properties				
Piezo ceramic	PICMA® P-885	PICMA® P-885		
Electrical capacitance	6 (X, Y)	6 (X, Y), 12 (Z)	μF	±20 %
Miscellaneous				
Operating temperature range	15 to 40	15 to 40	°C	
Material	Aluminum	Aluminum		
Mass	1	1.2	kg	±5 %
Cable length	1.7	1.7	m	+10 cm
Piezo controller	E-727.3CDA (included in scope of delivery)			
Communication interfaces	Ethernet, USB, RS-232, serial SPI high-speed interface			
Analog input / Analog output	Sub-D (15-pin), Input via 18-bit A/D converter Output via 20-bit D/A converter			
Command set	PI General Command Set (GCS)			
User software	PIMikroMove			
Software drivers	LabVIEW drivers, shared libraries for Windows and Linux			
Supported functions	Function generator, data recorder, drift compensation, macros			

Accessories: P-545.PD3,
Petri dish holder, dimensions in mm

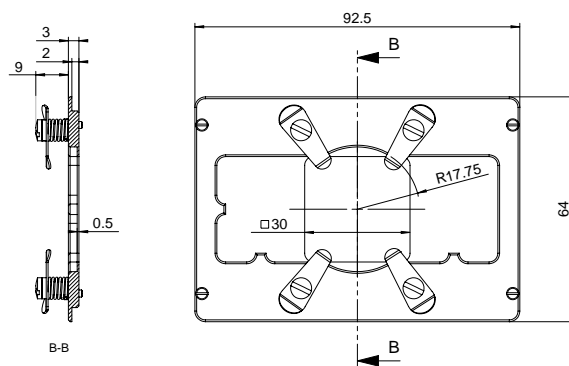

Accessories: P-545.SH3,
microscope slide holder, dimensions in mm

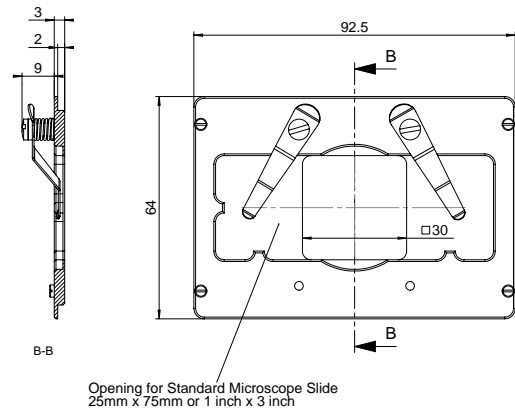

* With flexure guides, the resolution is not limited by friction. Value given is noise equivalent motion measured with interferometer.
** For dynamic operation. Higher dynamics are possible with a reduced load.

Ask about custom designs!

E-727 Digital Multi-Channel Piezo Controller

For Nanopositioning Systems with Capacitive, Piezoresistive or Strain Gauge Sensors



>> Extensive Software Package

Technology Glossary page 76

- 25 kHz control bandwidth
- Interfaces: Ethernet, USB and RS-232
- Digital inputs and outputs
- Optional analog inputs and outputs
- Auto-loading of calibration data from stage ID chip for interchangeability of controller and mechanics
- 4th order polynomial linearization for mechanics and electronics

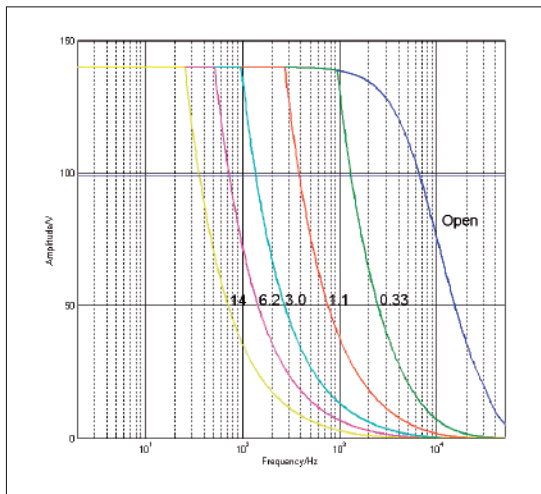
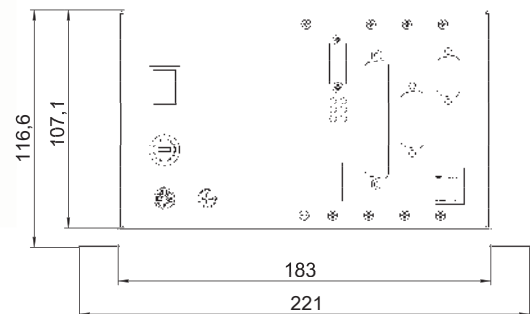

E-727: Operating limits (open-loop) with various capacitive loads, capacitance values in μF

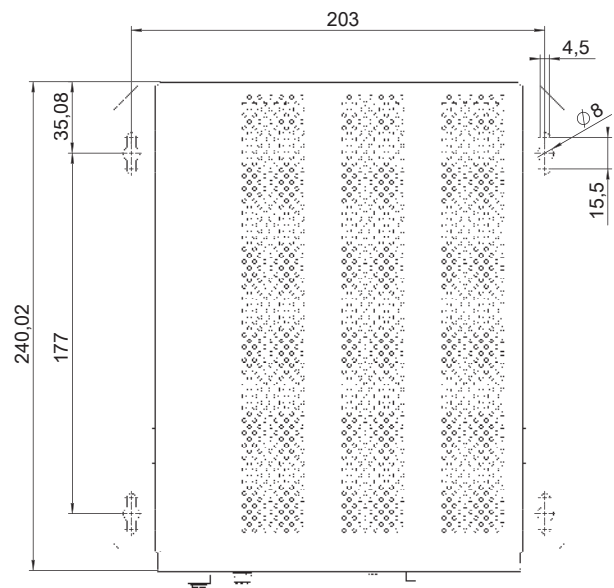

E-727, dimensions in mm

	E-727	Unit	Tolerance
Processor	DSP 32/64-bit, floating point, 375 MHz		
Sampling rate, servo-control	20	kHz	
Sampling rate, sensor	100	kHz	
Sensor			
Servo characteristics	P-I, two notch filters / Optional: Advanced piezo control		
Sensor channels	3	kHz	max.
Sensor resolution	20	Bit	at 1 kHz over-sampling
Amplifier			
Output voltage	-30 to 130	V	±3 V
Amplifier channels	4		
Peak output power per channel, max. 30 ms	28	W	max.
Average output power per channel	14	W	max. 300 ms
Peak current per channel, max. 30 ms	200	mA	max.
Average output current per channel	100	mA	max.
Current limitation	Short-circuit-proof		
Resolution DAC	20	Bit	
Amplifier bandwidth	6.5	kHz	
Interfaces and operation			
Interface / communication	Ethernet, USB, RS-232, serial SPI high-speed interface		
Analog inputs	Sub-D, 15-pin, 4 inputs, via 18-bit A/D converter		±10 V
Analog output	Universal output, via 20-bit D/A converter		±10 V
Digital input/output	MDR14; 4 inputs, 4 outputs		
Command set	PI General Command Set (GCS)		
User software	PI MikroMove		
Software drivers	LabVIEW driver, shared libraries for Windows and Linux		
Supported functions	Wave generator, data recorder, drift compensation, macros		
Display and indicators	LEDs for Power, Servo, Error, Overflow		
Linearization	4th order polynomials, DDL (Dynamic Digital Linearization)		
Separate protective earth connection	Yes		
Miscellaneous			
Operating temperature range	5 to 40	°C	
Overheat protection	Max. 72 °C, deactivation of the piezo voltage output		
Mass	2.4 to 2.6	kg	approx.
Power consumption	80	W	max.
Power consumption without load	24	W	max.
Operating voltage	24 VDC (external power supply in the scope of delivery)		
Dimensions	221 mm x 117 mm x 240 mm (incl. mounting rails)		

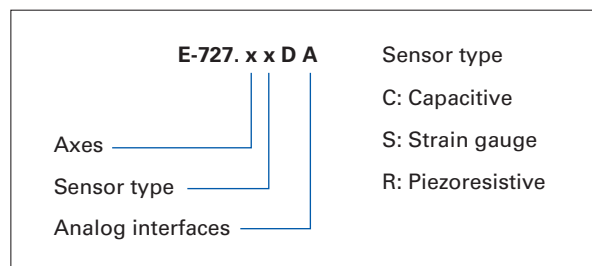

Engineered Systems Capabilities



Precision components, stable control and a great deal of experience in engineering are essential for high-precision complex motion and positioning solutions. PI is a supplier of technologically sophisticated drive components and high-precision positioners and also offers all levels of integration up to the turnkey solution.

Engineering services have been a part of PI's core business for many years. Complete solutions, fitting seamlessly into existing processes, advance automation in major research installations as well as manufacturing and inspection processes for chip production or photonics packaging.



Wafer inspection system with integrated linear motor axes for fast precision XY scanning. Stepper motor axis for fine vertical position of the inspection equipment

Core Competences

- Application support and consulting for motion and positioning applications
- Reliable and prompt series production even for large quantities
- Economic design
- Commissioning of turnkey solutions
- Complex multi-axis designs and parallel kinematic robotics
- Broad spectrum of technologies: Drive, guide, and sensor technologies
- In-house motion control electronics and software platform
- Customized software integration such as Epics, LabVIEW, Tango, ...

FROM THE INITIAL DESIGN TO COMMISSIONING: WORKING TOGETHER FOR THE BEST SOLUTION

Steps towards success:

- Define together what the exact purpose of your question or application is
- Close cooperation with you on an engineering design level during the concept phase to find the perfect solution
- Technical and business proposal
- Detailing the complete system
- The system is assembled, tested, approved by the customer and then delivered



“The most important thing is to understand the customer’s task. Our engineers have extensive experience in implementing and qualifying the systems. In order to achieve the maximum benefit, we also consider the local constraints right from the very beginning.”

Dr. Marthe Kauffholz,
Head of Product Division
Engineered Systems

ENGINEERED SYSTEMS USE TOP-QUALITY COMPONENTS

The key to success is that the entire knowledge and experience of the PI family is used for creating customized products for individual applications. Customized solutions are made easy with the broad portfolio of standard products available from one supplier.

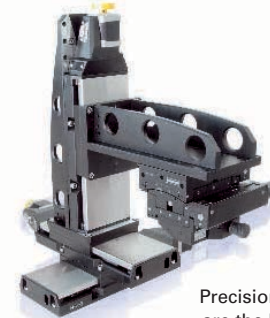

Precision components
are the basis for high-
quality multi-axis designs

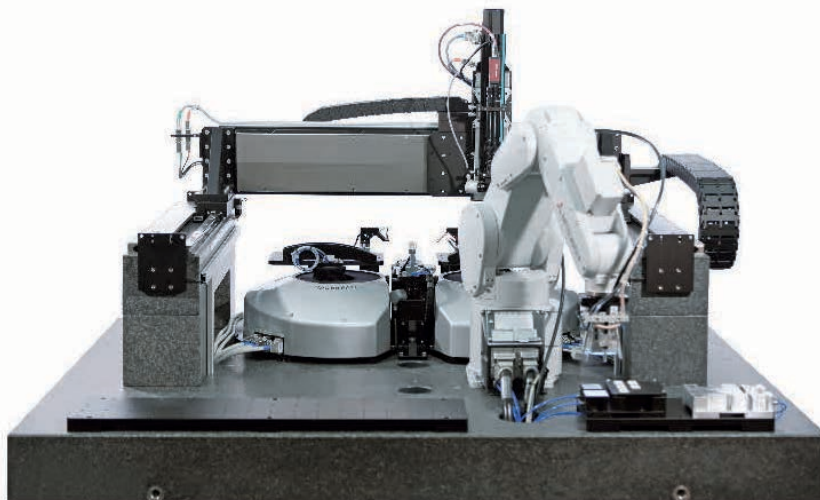

Complex multi-axis designs and fully integrated systems are available, like this assembly system for photonics packaging

PI provides all the components for the system and integrates these into a turnkey machine for production or inspection.

- Micro- and nanopositioners
- Handling and robot elements
- Machine vision
- Software integration

F-712.HA1/F-712.HA2 High-Precision Fiber Alignment System

System with 6 Degrees of Freedom for Aligning Fibers and Optical Components

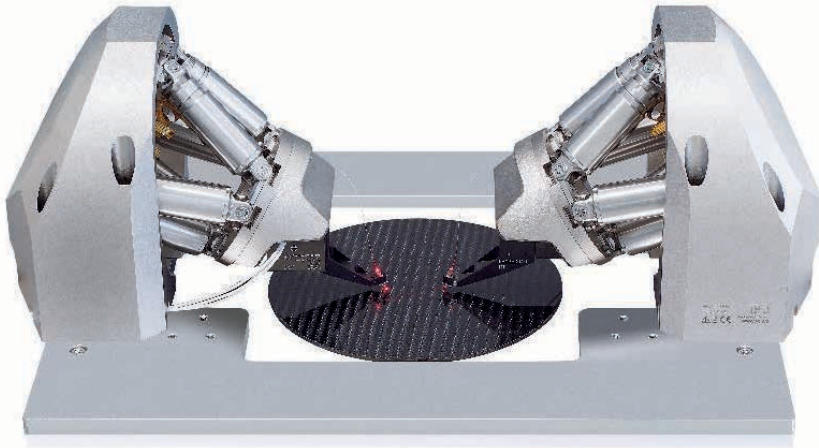

- >> Extensive Software Package
- >> Flexure Guiding Systems
- >> Parallel Kinematics
- >> PICMA® Multilayer Piezo Actuators

Technology Glossary page 76

- Integrated scan routines for fiber optic alignment
- Ideal for applications in silicon photonics
- Direct detection of the optical signal
- Position sensors for high accuracy and operational reliability
- Automatic alignment of several fibers in <1 s
- Stiff set-up of H-811 hexapod and P 616 NanoCube® nanopositioner
- Single- and double-sided system available, for simultaneous alignment of the transmitter and receiver

F-712.HAx, dimensions in mm

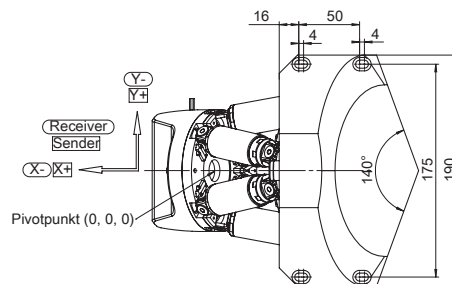
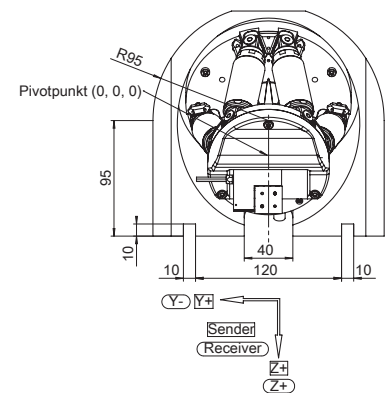
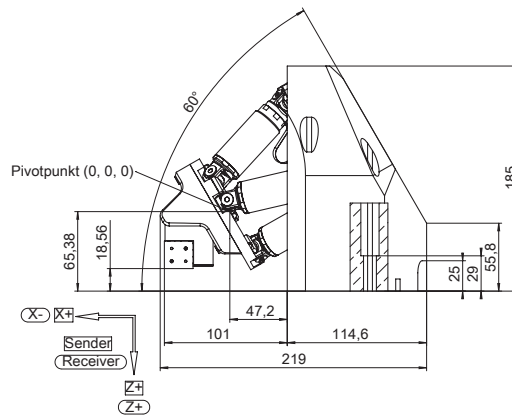

The detailed description including all data is on our homepage at www.pi.ws

Preliminary data	F-712.HA1 / F-712.HA2	Unit
Motion and positioning		
Rough positioning		
Active axes	X, Y, Z, θ_x , θ_y , θ_z	
Travel range in X, Y, Z	± 6.5 , ± 16 , $\pm 8.5^*$	mm
Travel range in θ_x , θ_y , θ_z	± 14.5 , ± 10 , $\pm 10^*$	°
Minimum incremental motion	0.1	μm
Max. velocity	10	mm/s
Sensor type	Rotary encoder	
Guiding	–	
Drive type	Brushless DC motor	
Fine positioning		
Active axes	X, Y, Z	
Closed-loop travel in X, Y, Z	100	μm
Min. incremental motion, open-loop	0.3	nm
Min. incremental motion, closed-loop	2.5	nm
Linearity error, for the entire travel range**	2	%
Repeatability (bidirectional) 10 % travel range	2	nm
Sensor type	Incremental	
Drive type	PICMA®	
Alignment		
Alignment time area scan 100 μm x 100 μm (max. deviation of peak intensity 0.02 dB)***	<0.5 / <1	s
Alignment time gradient search, randomized with $\pm 5 \mu\text{m}$ (repeatability <0.01 dB)***	<0.5 / <1	s
Miscellaneous		
Operating temperature range, mechanics	0 to 50	°C
Operating temperature range, controller	5 to 40	°C
Cable length	2	m

	Requirements for the photometer used	Unit
Output signal	Analog output, ideally converted from linear to logarithmic	
Output voltage range, max.	–5 to 5	V
Bandwidth, min.	1	kHz
Noise level, max.	–60	dBm

Technical data specified at 20±3 °C.

* The travel ranges of the individual coordinates (X, Y, Z, θ_x , θ_y , θ_z) are interdependent. The data for each axis in this table shows its maximum travel range, where all other axes and the pivot point are at the reference position. See the dimensional drawings for the default coordinate system and pivot point coordinates of the hexapod. Changing the pivot point will reduce the travel range in θ_x , θ_y , θ_z . Changing the orientation of the coordinate system (e.g., when the optical axis is to be the Z axis), will change the travel range in X, Y, and Z.

** Without polynomial linearization

*** Reaching the global maximum after first light has been found

Ask about custom designs!

F-712.MA1 / F-712.MA2

High-Precision Fiber Alignment System

Stacked Multi-Axis System for Aligning Fibers and Optical Components



- >> Extensive Software Package
- >> Flexure Guiding Systems
- >> PICMA® Multilayer Piezo Actuators

Technology Glossary page 76

- Integrated scan routines for fiber optic alignment
- Ideal for applications in silicon photonics
- Direct detection of the optical signal
- Position sensors for high accuracy and operational reliability
- Automatic alignment of several fibers in <1 s
- Stiff XYZ set-up of motorized stages and P-616 NanoCube® nanopositioner
- Single- and double-sided system available, for simultaneous alignment of the transmitter and receiver

F-712.MAx, dimensions in mm

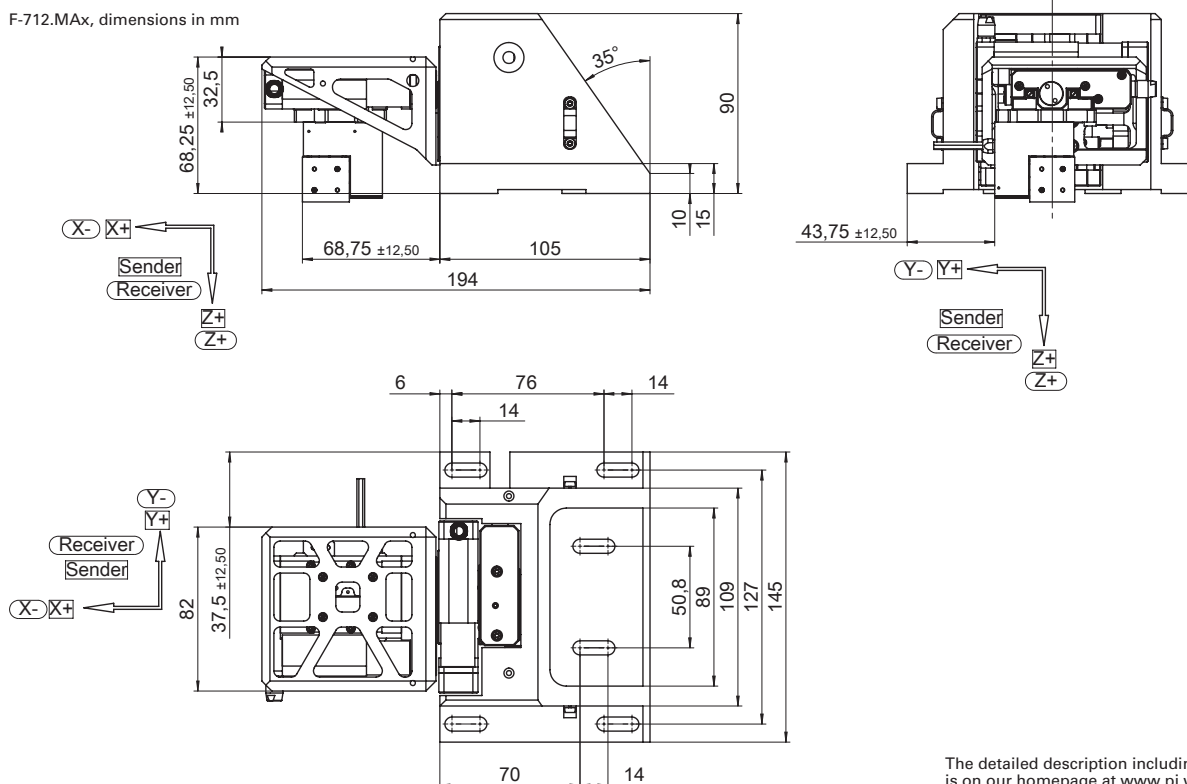

The detailed description including all data is on our homepage at www.pi.ws

Preliminary data	F-712.MA1 / F-712.MA2	Unit
Motion and positioning		
Rough positioning		
Active axes	X, Y, Z	
Travel range in X, Y, Z	25, 25, 25	mm
Minimum incremental motion	3	µm
Max. velocity	20	mm/s
Sensor type	Rotary encoder	
Guiding	Crossed roller guides	
Drive type	DC motor	
Fine positioning		
Active axes	X, Y, Z	
Closed-loop travel in X, Y, Z	100	µm
Min. incremental motion, open-loop	0.3	nm
Min. incremental motion, closed-loop	2.5	nm
Linearity error, for the entire travel range**	2	%
Repeatability (bidirectional) 10 % travel range	2	nm
Sensor type	Incremental	
Drive type	PICMA®	
Alignment		
Alignment time area scan 100 µm x 100 µm (max. deviation of peak intensity 0.02 dB)***	<0.5 / <1	s
Alignment time gradient search, randomized with ±5 µm (repeatability <0.01 dB)***	<0.5 / <1	s
Miscellaneous		
Operating temperature range, mechanics	-20 to 65	°C
Operating temperature range, controller	5 to 40	°C
Cable length	3	m
Requirements for the photometer used		
Output signal	Analog output, ideally converted from linear to logarithmic	
Output voltage range, max.	-5 to 5	V
Bandwidth, min.	1	kHz
Noise level, max.	-60	dBm

Technical data specified at 20±3 °C.

* Without polynomial linearization

** Attainment of the global maximum after first light has been found

Ask about custom designs!

F-712.HU1

Fast Multi-Channel Photonics Alignment System

System with 6 Degrees of Freedom for Aligning Fibers and Optical Components



- >> Extensive Software Package
- >> Flexure Guiding Systems
- >> Parallel Kinematics
- >> PICMA® Multilayer Piezo Actuators

Technology Glossary page 76

- Integrated high-performance scan routines for fiber optic alignment
- Ideal for applications in silicon photonics
- Direct detection of the optical signal
- Position sensors for high accuracy and operational reliability
- Automatic alignment of several fibers in <1 s
- Stiff set-up with an H-811 hexapod and a P-616 NanoCube® nanopositioner

F-712.HU1, dimensions in mm

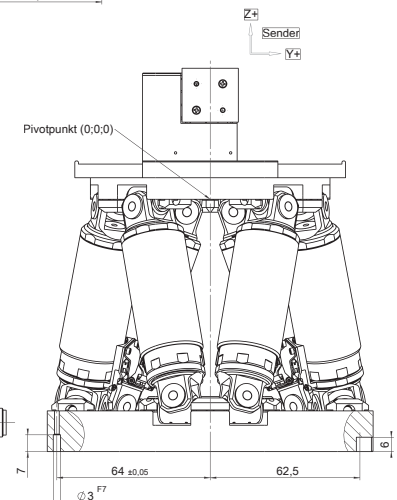
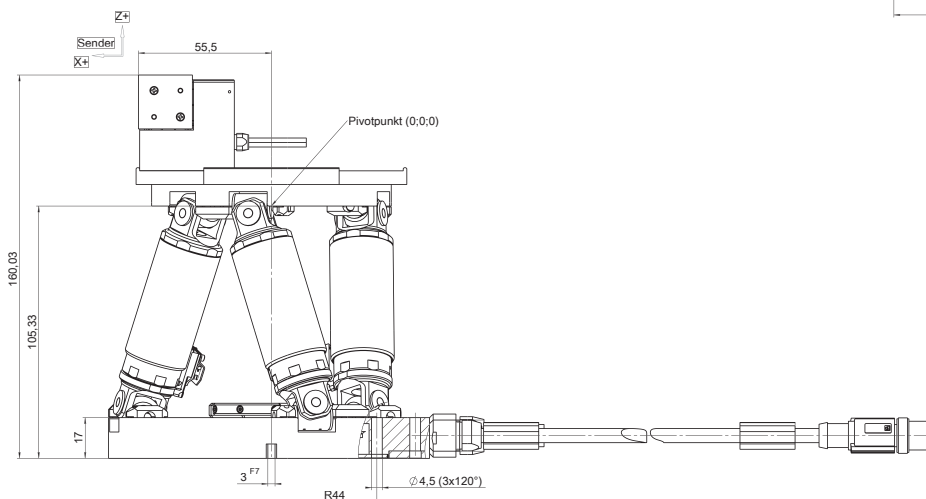
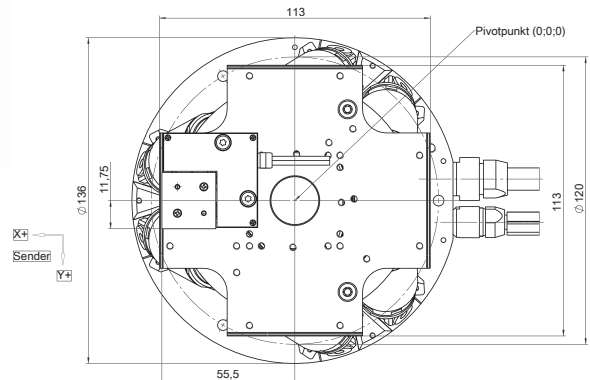

Preliminary data	F-712.HU1	Unit
Motion and positioning		
Rough positioning		
Active axes	X, Y, Z, θ_x , θ_y , θ_z	
Travel range in X, Y, Z	± 17 , ± 16 , $\pm 6.5^*$	mm
Travel range in θ_x , θ_y , θ_z	± 10 , ± 10 , $\pm 21^*$	°
Minimum incremental motion in X, Y	0.1	μm
Minimum incremental motion in Z	0.05	μm
Max. velocity	10	mm/s
Sensor type	Incremental rotary encoder	
Drive type	Brushless DC motor	
Fine positioning		
Active axes	X, Y, Z	
Closed-loop travel in X, Y, Z	100	μm
Min. incremental motion, open-loop	0.3	nm
Min. incremental motion, closed-loop	2.5	nm
Linearity error, for the entire travel range**	2	%
Repeatability (bidirectional) 10 % travel range	2	nm
Sensor type	Incremental linear encoder	
Drive type	PICMA®	
Alignment		
Alignment time area scan 100 μm x 100 μm (max. deviation of peak intensity 0.02 dB)***	<0.5	s
Alignment time gradient search, randomized with $\pm 5 \mu\text{m}$ (repeatability <0.01 dB)***	<0.5	s
Miscellaneous		
Operating temperature range, mechanics	0 to 50	°C
Operating temperature range, controller	5 to 40	°C
Cable length	2	m
Requirements for the photometer used		Unit
Output signal	Analog output, ideally converted from linear to logarithmic	
Output voltage range, max.	-5 to 5	V
Bandwidth, min.	1	kHz
Noise level, max.	-60	dBm

Technical data specified at 20±3 °C.

* The travel ranges of the individual coordinates (X, Y, Z, θ_x , θ_y , θ_z) are interdependent. The data for each axis in this table shows its maximum travel range, where all other axes and the pivot point are at the reference position. See the dimensional drawings for the default coordinate system and pivot point coordinates of the hexapod. Changing the pivot point will reduce the travel range in θ_x , θ_y , θ_z . Changing the orientation of the coordinate system (e.g., when the optical axis is to be the Z axis), will change the travel range in X, Y, and Z.

** Without polynomial linearization

*** Reaching the global maximum after first light has been found

Options and Capabilities for Piezo Electrics

PI Ceramic: Leaders in Piezo Technology for Individual Solutions

Flexible Adjustment of Actuators & Components

PI Ceramic is one of the world's leading manufacturers of piezo technology and an important development and production site of the PI Group. The fast and flexible adaptation of standard products to special areas of application is one of the core skills.

All process steps to the production and subsequent processing such as gluing and contacting the piezo elements take place in-house. This enables flexible adaptation of product, manufacturing, and test parameters for fast prototyping and, for later series in medium to large quantities up to some 1,000,000 pieces per year. Automated processes secure the constant high quality and keep costs low.

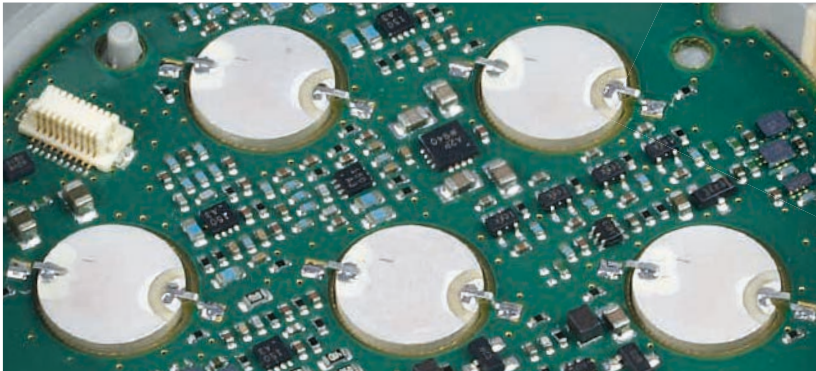

Piezo ceramics can be directly integrated on a printed circuit board, conveniently contacted with flexible boards, or fully encapsulated inside a housing supplied by the customer

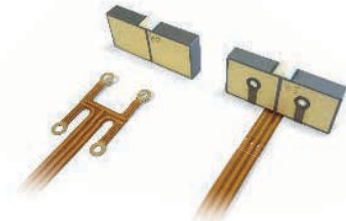

OEM Solutions and Application-Oriented Advice

The piezo specialists at PI Ceramic give extensive advice on system design to achieve optimum performance. Adaptation to the respective application includes selecting the optimum piezo material, shaping and contacting. PI Ceramic also supports during integration of the piezo elements with both advice and specific mechanical design. PI Ceramic takes care of all work steps reliably during the electrical and mechanical assembly.

PI Ceramic also offers specialized control electronics for piezo actuators ranging from laboratory devices to miniaturized OEM formats.

From piezo ceramic powder to sophisticated multi-axis nanopositioning devices: PI Ceramic plays an important role in PI's strategy of vertical integration

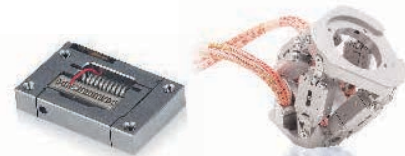

Latest Product News



PIEZO COMPONENTS WITH FLEXIBLE PRINTED CIRCUITS

- Easy Integration
- Customizable
- Secure contacting
- Support for adapted design

SPHERICAL PIEZO TRANSDUCERS

- Use in 360° Ultrasonic Applications
- Wall thickness from 0.2 mm
- Diameters between 2 and 100 mm
- Range of piezo material adapted to application



ROUND PICMA® STACK MULTILAYER ACTUATORS

- High blocking force
- Superior lifetime
- Ideal for dynamic operation
- Flexible, adaptable overall height
- OEM versions available without stranded wires

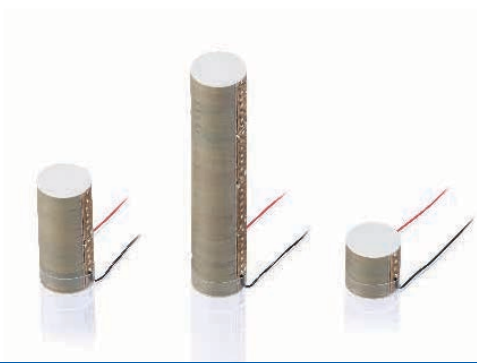

CUSTOMIZED PIEZO COMPONENTS

- Customizable, ideal for prototyping
- Miniaturized piezo tubes, rings, spheres and hemispheres
- Sophisticated production technology



The detailed description including all data is on our homepage at www.piceramic.com.

Technology Glossary

Capacitive Sensors

Capacitive sensors allow contactless measuring, do not introduce much energy into the piezo drive system and have a flat design. Their direct position measurement of the piezo actuators eliminates drift effects for travel ranges of up to 1.5 mm. The overall system, which consists of the stage, sensor technology, and electronics, gains on performance and precision. Due to noncontact measuring in the 10 µm up to approx. 2 mm range, it is possible to mount the capacitive sensor in the stage at the point where the motion actually takes place. The design consists of two conductive surfaces: A high-frequency alternating current generates a homogenous electric field between the two surfaces.

Customers from the semiconductor industry also appreciate the small and versatile design as well as the lack of thermal build-up in the system.

Direct Metrology

Position measuring is performed with the highest accuracy directly at the motion platform so that nonlinearity, mechanical play or elastic deformation have no influence on position measuring. Precision positioning systems use different encoder types as position sensor: Incremental encoders with different accuracy levels, absolute-measuring encoders that additionally make referencing unnecessary when a machine is switched on again, and for travel ranges under 2 mm, capacitive sensors.

Extensive Software Package

To make systems more user friendly, software plays an important role in positioning systems. Customers expect a plug-and-play solution even if several positioning systems are combined or different drive systems need to interact, and that's why PI (Physik Instrumente) provides PIMikroMove® host software. You only need to enter your parameters into the application to avoid programming altogether. PI (Physik Instrumente) also supports a number of text-based languages, has its own Python and Matlab drivers, and the software is compatible with Windows, Linux, and OSX.

Flexure Guiding Systems

Piezo systems from PI (Physik Instrumente) use lever-amplified piezo actuators as the drive, e.g. when adjusting optical lenses. For optimum results regarding dynamics and accuracy, it is necessary to ascertain and optimize the mechanical and piezoelectric properties such as the guiding accuracy, crosstalk or temperature-related drift in the overall system. Friction-free flexure guides that allow hysteresis-free motion steer the motion and retain the stiffness. Very small, but subnanometer precision motion is transferred to the required system motion by using lever amplification.

Parallel Kinematics, Hexapods

Hexapods are parallel-kinematic systems with six drives that are connected directly to a single platform. This makes it possible for users to position objects automatically in all degrees of freedom, X, Y, Z, and rotatory and, depending on the drive, with an accuracy in the micrometer range or lower. The parallel-kinematic system is very stiff, with only a low passive weight to move and, with the corresponding design, can carry loads of up to several tons. Users are able to arbitrarily choose the reference coordinate system and, today, workers are now working together with hexapods on the production line. The user integrates the system into the automation environment via EtherCAT.

PICMA® Multilayer Piezo Actuators

PICMA® actuators take advantage of the indirect piezoelectric effect and achieve high forces with relatively low voltages. They only need a small amount of installation space. At the same time, the PICMA® actuators are very dynamic and can reach a position with a hitherto unattained precision. This is the reason why they are used as micropumps in metering technology. Due to their ceramic insulation, PICMA® actuators exhibit high reliability and climate resistance. PI (Physik Instrumente) also equips PICMA® actuators with individual connections for customer applications.

PiezoWalk® Walking Drive

PiezoWalk® drives take advantage of the piezo walking principle and combine a subnanometer resolution with high forces, a robust design, and a scalable travel range. Industry customers use walking drives for travel ranges greater than 1 mm and to hold a stable position with nanometer precision resolution. PI (Physik Instrumente) offers walking drives with high feed forces as well as positioning and holding forces, but also relatively high velocities, and they also have a long lifetime in a vacuum.

PIglide Air Bearing Technology

The PIglide air bearing technology allows friction-free positioning with a high guiding accuracy of up to 5 μ rad over 100 mm. The technology improves the position resolution and it is possible to realize constant-velocity scanning. The repeatability is only a few encoder impulses. A similar precision in the nanometer range is also possible with flexure-guided piezo nanopositioners, however, only over considerably shorter travel ranges. The developers at PI (Physik Instrumente) adapt high-precision, air bearing positioning stages and motion control systems according to customer requirements.

PILine® Ultrasonic Piezomotors

PILine® Ultrasonic piezomotors are precise, dynamic, small, and silent, and replace classical drive technologies, because the drives are also self-locking. As a result, they don't have to be supplied with current when at rest and that, in turn, reduces the energy requirements of the application. For this reason and due to their small size, the drives are very popular for mobile devices in the optical industry and measuring technology.

PIMag® Magnetic Linear Motors

Magnetic direct drives from PI (Physik Instrumente) provide a direct and stiff connection between the load to be moved and the drive. The industry demand is particularly high when objects need to be positioned with high dynamics and precision. Thanks to the smooth-running precision linear guides with crossed roller bearings, these types of linear motor stages are particularly suitable for applications that require constant-velocity scanning. The drives operate without contact and therefore very reliable. Users can integrate the magnetic direct drives into existing machines and systems quickly and easily via standardized fieldbus systems.

PIMag® Voice Coil

Thanks to their low weight and friction-free drive principle, voice coil drives are small and particularly suitable for applications that require high dynamics and high velocities over limited travel ranges - for example, in medical technology. Voice coil drives have a greater advantage for the customer when compared to traditional drive screw-based solutions, particularly with respect to wear and dynamics.

High scan frequencies and precision positioning are possible with these drives, because they are free of hysteresis effects.

Q-Motion® Piezoelectric Inertia Drive

Piezo inertia drives are space-saving and affordable piezo-based drives with relatively high holding forces and a virtually unlimited travel range. With an operating frequency of up to 20 kHz, the drives reach velocities of more than 5 mm/s that act directly on the runner. The Q-Motion® drive operates silently at the maximum operating frequency of 20 kHz. When at rest, the drive is self-locking, requires no current, and does not generate any heat. It holds the position with maximum force. It is therefore suitable for battery-powered, mobile applications with a low number of load cycles.

Vacuum-Compatible Versions

In a large number of industry sectors, production in a vacuum is becoming increasingly more important. Therefore, PI (Physik Instrumente) offers various different drive technologies to its customers that can be operated in a vacuum of 10^{-7} or even 10^{-10} hPa. This includes piezo actuators that work in strong magnetic fields and in a cryogenic environment, piezo systems with travel ranges lower than 1.5 mm and subnanometer precision, piezomotors in a variety of designs with respect to force, dynamics, and travel range, as well as classical motorization with specially designed DC or stepper motors, that allow greater travel ranges.

The PI Group Milestones

A Success Story

Well known for the high quality of its products, PI (Physik Instrumente) has been one of the leading players in the global market for precision positioning technology for many years. PI has been developing and manufacturing standard

and OEM products with piezo or motor drives for more than 40 years. In addition to four locations in Germany, the PI Group is represented internationally by fifteen sales and service subsidiaries. All of our customers worldwide can rely on this.

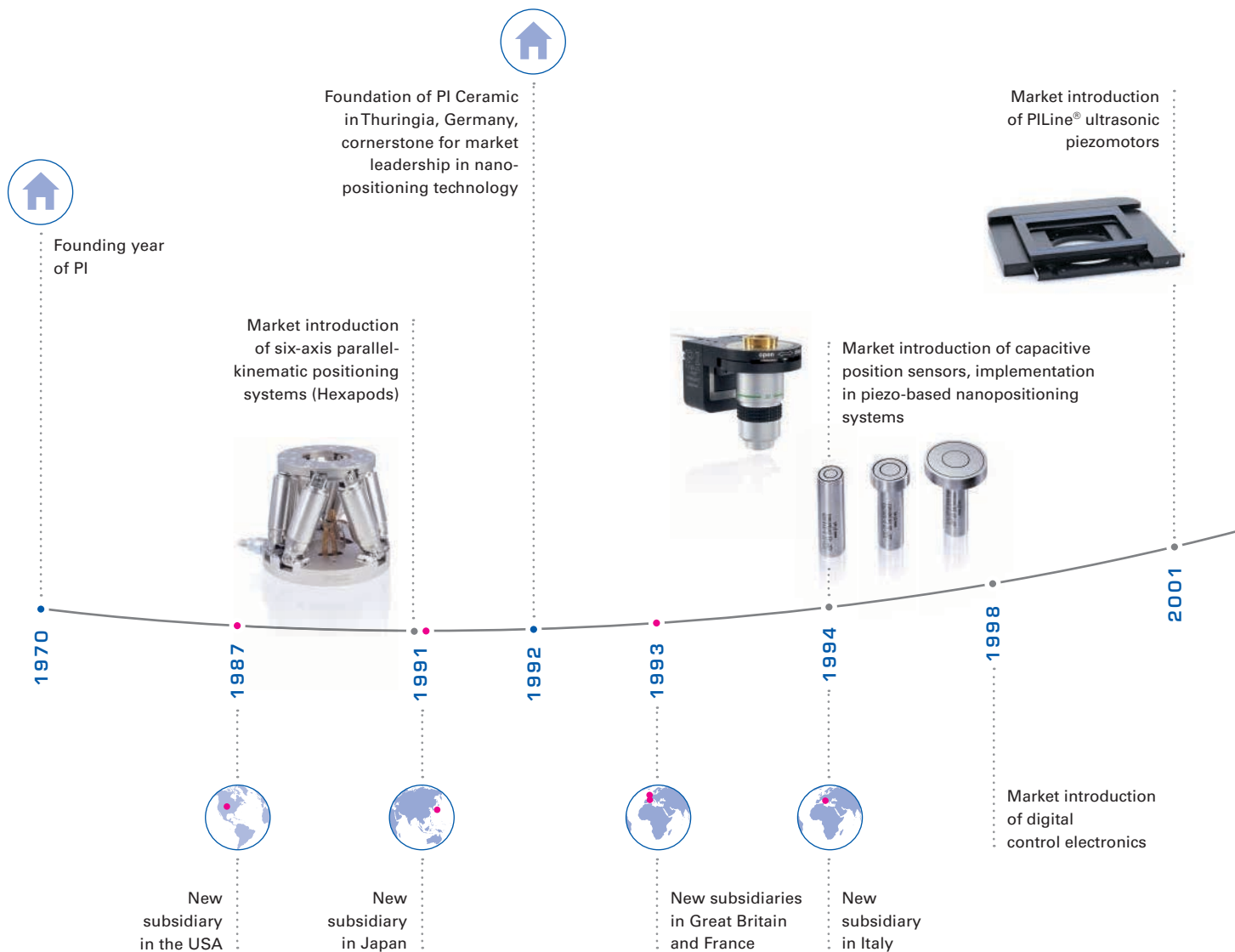

PI USA

USA and Canada (East)

PI (Physik Instrumente) L.P.
16 Albert St.
Auburn, MA 01501
Phone +1 508 832-3456
Fax +1 508 832-0506
info@pi-usa.us
www.pi-usa.us

USA (West) / Mexico

PI (Physik Instrumente) L.P.
5420 Trabuco Road, Suite 100
Irvine, CA 92620
Phone +1 949 679-9191
Fax +1 949 679-9292

San Francisco Bay Area Office

PI (Physik Instrumente) L.P.
1 Harbor Drive, Suite 108
Sausalito, CA 94965
Phone +1 408-533-0973
Fax +1 949-679-9292

Headquarters

GERMANY

Physik Instrumente (PI) GmbH & Co. KG
Auf der Roemerstrasse 1
76228 Karlsruhe
Phone +49 721 4846-0
Fax +49 721 4846-1019
info@pi.ws
www.pi.ws

PI miCos GmbH
Eschbach
info@pimicos.com
www.pi.ws

PI Ceramic GmbH
Lederhose
info@piceramic.com
www.piceramic.com

FRANCE

PI France S.A.S.
Aix-en-Provence
www.pi.ws

UK & IRELAND

PI (Physik Instrumente) Ltd.
Cranfield, Bedford
www.physikinstrumente.co.uk

ITALY

Physik Instrumente (PI) S. r. l.
Bresso
www.pionline.it

NETHERLANDS

PI Benelux B.V.
Sint-Oedenrode
www.pi.ws/benelux

SPAIN

Micos Iberia S.L.
Vilanova i la Geltrú
www.pimicos.es

KOREA

PI Korea Ltd.
Seoul
www.pikorea.co.kr

JAPAN

PI Japan Co., Ltd.
Tokyo
www.pi-japan.jp

PI Japan Co., Ltd.
Osaka
www.pi-japan.jp

CHINA

Physik Instrumente (PI Shanghai) Co., Ltd.
Shanghai
www.pi-china.cn

Physik Instrumente (PI Shanghai) Co., Ltd.
Beijing
www.pi-china.cn

SOUTHEAST ASIA

PI (Physik Instrumente) Singapore LLP
Singapore
www.pi-singapore.sg
For ID / MY / PH / SG / TH / VNM

TAIWAN

Physik Instrumente (PI) Taiwan Ltd.
Taipei
www.pi-taiwan.com.tw

Well-Positioned All Over the World

The PI Group is present in all key technology regions world-wide. Its local representations around the globe are more than just sales agencies. Customers benefit from this in many ways:

- Service facilities for diagnosis and repair as well as metrology equipment for tests, system calibration and quality assurance
- R&D departments, which are able to react promptly to the demands of the local markets and ensure a direct dialog with the customers
- Sample and prototype construction – in close contact with development departments and customers
- Sales and application engineers – experts for the entire product portfolio of the PI Group and your contact for customized developments – from the initial consultation to the delivery
- Market and business development experts who listen to what customers in specific market segments want and enable the PI Group to develop products that fulfill these requirements.

© Physik Instrumente (PI) GmbH & Co. KG
All contents, including texts, graphics, data etc., as well as their layout, are subject to copyright and other protective laws. Any copying, modification or redistribution in whole or in parts is subject to a written permission of PI.

Although the information in this document has been compiled with the greatest care, errors cannot be ruled out completely. Therefore, we cannot guarantee for the information being complete, correct and up to date. Illustrations may differ from the original and are not binding. PI reserves the right to supplement or change the information provided without prior notice.